

# **OPERATORS MANUAL FOR Encore DHR**



801 Burton Blvd. DeForest WI 53532  
Ph: 608-846-7016 Fax: 608-846-1024  
E-mail: [info@aglaminators.com](mailto:info@aglaminators.com)

Table of Contents

**Chapter 1 Installation**

Selecting Area ----- 1-1  
 Uncrating ----- 1-1  
 Leveling ----- 1-1  
 Electrical Connection ----- 1-2  
 Pneumatic Connection ----- 1-2  
 Recycling Packaging ----- 1-2

**Chapter 2 Specifications**

Machine Dimensions -----2-1  
 Electrical Requirements -----2-1  
 Pneumatic Requirements -----2-1  
 Material Capacity -----2-1

**Chapter 3 Safety**

General Machine Safety -----3-1  
 Operator Safety -----3-1

**Chapter 4 Operation**

General ----- 4-1  
 Right Front Control Panel, Figure 1 -----4-2  
 Left Front Control Panel, Figure 2 -----4-3  
 Rear Control Panel, Figure 3 -----4-4  
 Top Control Panel, Figure 4 -----4-5  
 Web Tension Adjust, Figure 5 -----4-6  
 Windup Stations, Figure 6----- 4-6  
 Loading and Positioning Film ----- 4-7  
 Drop Down Infeed Table----- 4-7  
 Web the Laminator ----- 4-8  
 Encapsulation Process, Figure 7 ----- 4-8  
 Pressure Sensitive Top and Bottom Process, Figure 8 ----- 4-10  
 Pressure Sensitive Process, Reverse, Figure 9 -----4-12  
 Process Output Trouble Shooting -----4-14  
 Process Control Chart ----- 4-16  
 PLI Chart ----- 4-17

**Chapter 5 Maintenance**

Nip Roll Section -----5-1  
 Checking the Nip -----5-1  
 Zeroing the Nip ----- 5-1  
 Cleaning the Nip Rolls ----- 5-1  
 Roller Open and Close Rate -----5-2  
 Lubrication ----- 5-2  
 Electrical Schematic -----5-3  
 Pneumatic Schematic -----5-4

**Chapter 6 Warranty**

Limited Warranty ----- 6-1

## Selecting Area

Select an area that has a smooth, level surface for the laminator to set on, this will allow for easier maneuverability of the machine if it requires moving later on. The area should be large enough to allow an operator ample room to properly handle your largest product on the infeed and outfeed sides of the laminator. The sides of the laminator should also be easily accessible in case service or maintenance is required. AGL approximates this area should be about 7-8 feet in front and back of the machine and 3-4 feet on either end. This is only a suggestion, your plant and the products to be laminated will be the determining factor.

## Uncrating

Your new laminator may come in a full crate. The crate is designed to be usable for future shipping if required, so careful disassembly of the crate is important if the crate is to be reused. The crate is held together by screws (Phillips head) a power screwdriver with a Phillips bit is recommended but not required for uncrating. First, remove the top of the crate, keep the screws for future use on the crate. Next, remove the front of the crate (it is recommended that two people disassemble the crate, so one person can hold the panels while the other removes the screws). Move around the crate and remove the remaining panels. Remove the bolts holding the laminator down to the skid. A fork truck can now lift the laminator off the skid (it is possible to get the laminator out of the crate after removing only the top and front and the hold down bolts). With the laminator on the fork truck, thread the adjusting bolts into the lower cross bar, make sure that the bolt heads are about ½" above the caster. Lower the machine down onto the casters. With 3-4 people to guide the machine, roll the machine into the final position.



### **CAUTION**

*The laminator is a large heavy piece of equipment. Do not attempt to move the machine with one person. Injury is possible as well as permanent damage to the laminator. The laminator should only be rolled on a relatively smooth and level surface. Tipping or forcing the machine over large bumps can destroy the alignment of the rolls, idlers, and unwind/windup shafts. This alignment is required for proper lamination. Advanced Grieg Laminators, Inc.'s warranty does not cover malfunction of the machine due to improper handling of the machine during installation.*

Turn the leveling bolts down until they touch the floor. Remove the shrink wrap, bands, and protective coverings from the rolls.



### **CAUTION**

*Do Not use a knife or other sharp object to remove the shrink wrap from the laminator and the protective coverings from the rolls. This can cause irreparable damage to the laminator enclosures and rolls.*

## Leveling

The laminator has been trammed and burned in at the factory, but to insure the alignment of the machine it must be leveled in its final position. To level the machine, set a level on the upper front unwind/windup shaft. Turn the front leveling bolts until the bubble shows that the shaft is level. Repeat this procedure on the upper rear unwind/windup shaft. Next place the level across the upper unwind/windup shafts (front to rear) and adjust the leveling bolts to achieve a level reading. Repeat this procedure on the other end of the machine. Be sure to check the left to right level as it may have shifted when leveling from front to back. Repeat the previous procedures until you have a level reading at all four places. Tighten the jam nuts on the leveling bolts up tight against the lower cross bar to lock the bolts in place.



### **CAUTION**

*Do Not lift the casters more than ½" off the floor. This will cause the machine to be unstable.*

### Electrical Connection

Refer to the **Electrical Requirements** under Specifications for the proper requirements for your laminator. All connections to components and terminal blocks should be checked for tightness before initial startup. This will help avoid and electrical problems caused by connections that may have loosened due to vibration during shipping. A readily accessible disconnect device shall be incorporated into the fixed wiring circuit. The circuit breaker on the laminator is not considered a disconnect device. Consult a qualified, licensed electrician to ensure that the power supply for the machine is properly installed in your facility. Qualified personnel can remove the RH enclosure cover to allow access to the circuit breaker and grounding lug. Advanced Grieg Laminators, Inc. will not be responsible for damage caused by incorrect electrical installation. Before initial startup, check all switches to make sure they are in the off or open position.

### Pneumatic Connection

Refer to the Pneumatic Requirements under Specifications for the proper requirements for your laminator. The air supply should be clean, dry, and regulated. Failure to properly clean and dry the air supplied to the laminator will cause damage to the cylinders, valves, and clutches. The laminator is supplied with a 1/4npt port for your final connection located in the lower right rear of the machine.



### **CAUTION**

***The air supply to the laminator must be clean and dry. Particles and moisture can damage the cylinders, brakes and clutches.***

Before laminating with your new laminator, the open close rate of the nip and pull rolls must be checked. Refer to the maintenance section under **Roller Open and Close Rate**.

### Recycling Packaging

If your machine came in a fully enclosed crate, the crate can be stored flat for future use or dismantled and the wood can be recycled. The screws can be kept for future use of the crates or stored for some other use. The shrink wrap is not recyclable and should be thrown away. The foam protective coverings over the rolls can be recycled to be used for other shipping purposes.

**Machine Dimensions**

Width: 89"  
Height: 50"  
Depth: 43" with tables extended, 35" with tables folded down  
Weight: 2800 lbs.

**Electrical Requirements**

220/230 VAC single phase, 50/60 Hz, 60 Amp service

**Pneumatic Requirements**

Approximately 2-3 cfm at 90 psi line pressure supplied via your cleaned/dried/regulated plant air.

**Material Capacity**

Upper Rear Station: 7.0" Diameter x 62 long x 3" Diameter core. Standard  
Upper Front Station: 7.0" Diameter x 62 long x 3" Diameter core. Standard  
Lower Front Station: 7.0" Diameter x 62 long x 3" Diameter core. Standard  
Lower Rear Station: 7.0" Diameter x 62 long x 3" Diameter core. Optional

## IMPORTANT READ THIS SECTION BEFORE OPERATING YOUR LAMINATOR

### General Machine Safety

The following messages are written here for your safety, all operators and others around the laminator should read, understand and follow these messages.

1. Read and understand all the safety instructions.
2. Keep this manual in a place where it can be easily referenced by all operators.
3. **All connections to components and terminal blocks should be checked for tightness before initial startup. This will help avoid and electrical problems caused by connections that may have loosened due to vibration during shipping.**
4. Use only the recommended power source to run the laminator. Consult a qualified and licensed electrician if you are unsure of the power supply and the safety features of the supply.
5. If power supply cord is run across the floor, provide adequate protection to the cord to avoid damage from foot traffic, dropped items or rolling items.
6. Do not attempt to service the laminator without qualified personnel available. Damage to the machine or injury to you could be caused by moving parts or high voltage.
7. Do not operate the laminator with out all guards in place. If a guard is damaged or not working properly, replace or repair before returning the machine to operation. If the machine is run without all guards in place the safety obligation of the manufacturer is null and void.
8. Do not insert fingers, hands, or items into openings in the sideframes. Items may become entangled in moving parts or in contact with high voltage.
9. Disconnect or lockout power from machine when any service is required and when cleaning the nip rolls.
10. Disconnect or lockout power from the machine and refer to service personnel if the performance of the machine changes indicating a problem or if machine does not operate normally to correct operational procedures.
11. Adjust only items specifically covered by the operations portion of this manual. Any other adjustments may create problems in performance in your machine and may require servicing by qualified personnel to get machine back in correct working condition.

### Operator Safety

Your laminator is designed to protect the operator from injury when used properly. Do not operate the machine until you have read and understand this manual and without all guards and protection devices in place, serious injury could occur.



## WARNING

***The nip section can pull you into laminator! Do not place fingers into the nip section when the rolls are rotating. It is recommended that operators tie long hair back and not wear neckties, loose clothing and jewelry since they can be caught in the nip section and pull the operator into the machine. Proper equipment such as gloves should be used if the material being laminated requires it. The nip rolls will lower if there is a loss of air pressure.***

The nip section is protected by a photoelectric eye that shoots a light beam across the machine in front of the nip rolls. When the machine is in continuous run mode, the rolls will stop when the beam is broken by an item too close to the nip section. However, if the machine is in jog mode, an alarm will sound warning the operator that he/she is very close to the nip section, but the rolls will not stop rotating. The jog mode is useful for starting prints into the laminator and smoothing the print corners out as they enter the nip section, but this mode should be used as sparingly as possible since it puts the operator at a greater risk than the run mode.



## CAUTION

***When the machine is in jog mode, an alarm will sound to warn the operator but the rolls will not stop rotating when the light beam is broken. Use this mode sparingly and with respect.***

There are E-stop switches on all four corners of the machine, as well as an E-stop ribbon switch in front and back. The machine will stop and the nip section will open if any of these switches are tripped. Striking the red mushroom heads on the switches with your palm can activate the four switches. The ribbon switches can be tripped by stepping on the yellow ribbon. The machine must be reset after and E-stop condition has occurred. Refer to the **Operation** section for further details.

General

1. Power: A switch in the lower right rear switches the main power on and off. The switch is labeled clearly so the operator can tell if the power is on or off.
2. Reset: A reset button is used to start the machine initially and restart the machine after an E-stop condition has occurred. After the power is turned on, the reset button is held for 15 seconds to allow the machines electrical controls to reset to initial settings.
3. Speed: A potentiometer thumb wheel located on the top of the RH enclosure is used to control the speed that the laminator will run product through. Your laminator has the electrical and mechanical capability to run up to 15 feet per minute, but the quality of the product output is the governing factor in maximum process speed.
4. E-stops: E-stop switches are located at all four corners to allow the operator to stop the machine and open the nip rolls and pull rolls in case of emergency. The button must be pulled back out before pressing the reset button to restart the machine.
5. Nip Rolls: The nip rolls are the heart and soul of the laminator and must be cared for properly in order to give years of quality product output. Always dial the shim wheel to a shim setting greater than "0" when the machine is not in use. This will prevent the rolls from forming a flat spot from resting against each other. This also applies to the pull rolls.



**CAUTION**

***Always set the shim wheel to a setting greater than "0" when the machine is not in use. This will prevent the roll from coming together and forming a flat spot. Permanent damage can be caused to the rolls if this warning is not heeded.***

6. Fwd-Stop-Rev: There are a set of 3 buttons located on the top of the RH enclosure used to select the direction of the machine and to stop the machine. When standing in front of the machine, the green lit button that is farthest away from you is the reverse button, the red lit button is the stop button and the green lit button closest to you is the forward button.
7. Foot Switch: The foot switch will run the laminator in the direction depicted by the Fwd/Rev button and at the speed set by the potentiometer. The foot switch is always active, this allows an operator to press the foot switch to get a print started and then press the direction button to transfer to the continuous run mode without stopping.
8. Temperature Control with switch: The two position switch allows the operator to turn the heater in the roll on or off. The temperature controller allows the operator to set a desired temperature for a process.
9. Nip Roll open/close- This switch will open and close the nip rolls. When the switch selects the roll to close the switch will illuminate.
10. Pull Roll open/close- This switch will open and close the pull rolls. When the switch selects the roll to close the switch will illuminate.
11. Regulators- The regulators are used to control the air pressure to the cylinders for the nip and pull rolls. The regulator knob is turned clockwise to increase pressure and counter clockwise to decrease pressure.
12. Guages- The guages on the front and rear panels show the air pressure supplied to the nip and pull rolls. This will be a very repeatable reading that can be documented for quicker setups on jobs.

## Right Front Control Panel

The right front control panel looks like the figure below.



**Figure 1 Right Front Control Panel**

### Main Roller Controls:

The rocker switch will open and close the main nip rollers. The switch will illuminate when the rolls are selected to close. The pressure gauge is an indicator of how much pressure is being supplied to the nip roll cylinders. This pressure is critical to your processes, therefore the pressure gauge gives an accurate repeatable reference for quality product runs on your laminator. The regulator adjusts the pressure to the nip roll cylinders, clockwise to increase the pressure, counterclockwise to decrease pressure.

### Speed/Counter:

The speed display is optional on the DHR model. If equipped, the speed display will show the laminator speed in feet per minute. The display can also display linear feet of material used by pressing the "Sel" button to toggle between the speed and counter display. The display will show an "R" in the left side if the rate display is selected. If the display is in counter mode, the counter can be reset by pressing the "Rst" button. The display will go to 0 and begin counting up again.

### Power Indicator:

The power indicator light shows that power is supplied to the machine. If an emergency stop occurs, this light will go out.



### Left Front Control Panel

The left front control panel looks like the figure below.



**Figure 2. Left Front Control Panel**

#### Cooling Fans:

Cooling fans are optional on the DHR model. If equipped, the rocker switch will turn the cooling fans on and off. When the fans are turned on, the rocker switch will illuminate. An upper cooling station is also available.

#### Heat Controls:

To use the heat control, simply press the rocker switch to the on position. The only other setting the operator must change is the set point. To do this press and hold the star button and press the up or down arrow to adjust the setting. The led in the upper left of the control will illuminate and flash if controller is heating the coil up. The controller also has a built in overtemp alarm system to protect the rollers from overheating and destroying the roll coverings. If the roller temperature exceeds the factory preset value, the machine will go into an emergency stop mode and stop the machine. After the rolls have cooled down, the operator may attempt to restart the machine by pressing and holding the reset button on the right rear of the machine. If the rolls cause an emergency stop again, qualified service technicians should inspect the machine to solve the problem. Do not attempt to override this safety feature.

## Rear Control Panel



Figure 3. Rear Control Panel

**Pull Roller Controls:**

The rocker switch will open and close the main nip rollers. The switch will illuminate when the rolls are selected to close. The pressure gauge is an indicator of how much pressure is being supplied to the pull roll cylinders. This pressure is critical to your processes, therefore the pressure gauge gives an accurate repeatable reference for quality product runs on your laminator. The regulator adjusts the pressure to the pull roll cylinders, clockwise to increase the pressure, counterclockwise to decrease pressure.

**Reset Switch:**

This switch is for initial startup and resetting the machine after it has had an emergency stop. The button must be pressed and held for 15 seconds to allow the machine to go through a diagnostic setup.

## Top Control Panel

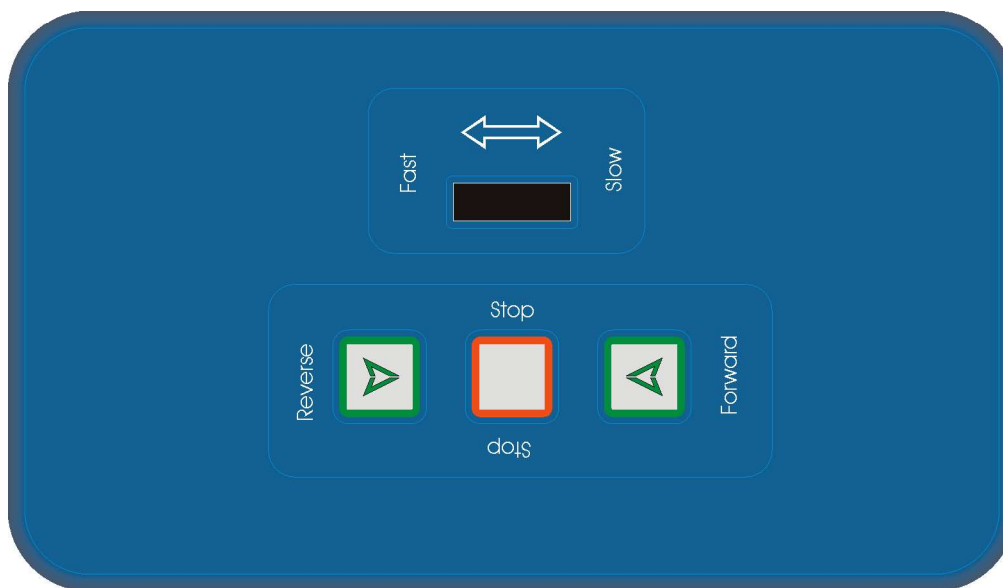

**Figure 4. Top Control Panel**

The top control panel is used to control the speed and direction of the machine. There are three buttons located to the left of the panel and a potentiometer wheel on the right. The potentiometer wheel controls the speed setting of the machine. As you push the wheel away from you (when standing in the front of the laminator) the speed will increase. There is a numerical display to reference for speed settings. If equipped, there may also be a digital speed readout on the front display.

Direction buttons:

The right button is for Forward, the middle button is for Stop, and the left button is for reverse. The buttons can be used in numerous ways depending on the operation required.

### Continuous mode from stop

To start the machine in continuous mode from a stop, press and hold the forward button, or reverse button for 4 seconds. The button selected will begin to flash and the machine will move in the direction selected if the photoeye is not blocked. If an object blocks the eye, the machine will return to stop mode.

### Jog mode

To start the machine in jog mode, press a direction button, it will illuminate. Press the footswitch and the machine will begin moving in the direction selected as long as the footswitch is pressed. The photoeye now only works as warning device. If the operator is holding down the footswitch and an object breaks the eye, a warning buzzer will sound but the rolls will not stop. This is useful when starting prints, but the operator must use this with extreme caution as it puts them at a high risk for injury.

### Jog to Continuous mode transfer

Follow the above steps in jog mode to start print, then while still holding down the footswitch, press the illuminated direction button again. The button will begin to flash and now the machine is in continuous run mode. The operator can step off the footswitch and the machine will continue to run.

**Note:** Sometimes the trailing edge of the print may curl up and trip the eye when in continuous run mode. This could stop the machine and lead to a ruined print. If the operator sees this is going to happen, simply step on the footswitch, if the eye trips the machine will go back to jog mode and can be manually run to get the print through. Press the direction button again to transfer to continuous run mode.

**Web Tension adjust**

The brakes on your machine are located on the unwind shafts near the left hand side of the machine. The brakes use compression of the delrin block on the shaft to create back tension on the web. For best results when laminating use the least amount of tension as possible for your application. The knob on the block will increase tension when turned clockwise and decrease tension when turned counterclockwise. An optional 10 bar LED display is available. The brake assembly is shown below.

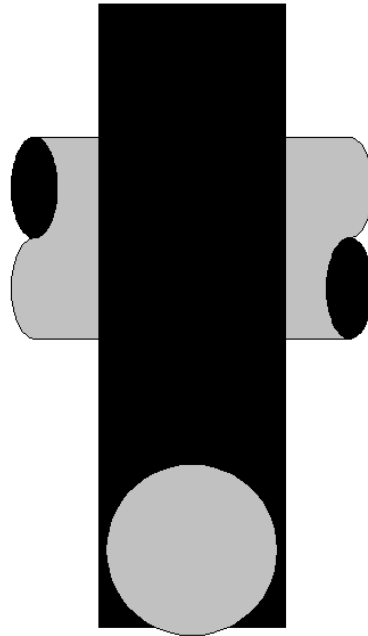

**Figure 5. Brake Assembly**

**Windup Stations**

The windup stations are used to take material up. The liner windup station which is located in front and above the nip rolls is used to windup the release liner of pressure sensitive film. There is also a product windup station available that winds up the finished product after it exits the pull rolls. This windup station is located underneath the pull rolls. The adjustment disc for these stations is located on the right hand side. The knurled disc is rotated away from the operator to increase the friction drive and toward the operator to decrease the friction drive. The adjustment disc assembly is shown below:

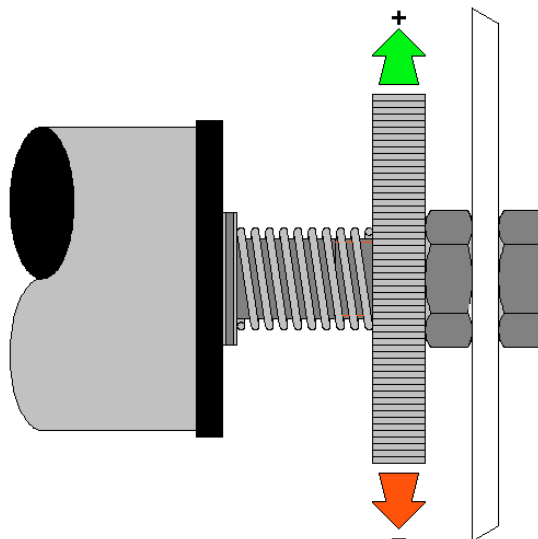

**Figure 6. Windup adjustment assembly**

## Laminator Setup

Your laminator has been designed to make the setup and lamination process as easy and repeatable as possible, however, there will be techniques that make this phase easier that you will only learn by using the machine. Do not get frustrated if the setup process takes longer than you expected, the process will get quicker and easier the more you use your laminator.

The set up process is comprised of the following steps:

1. Loading and positioning the film.
2. Webbing the laminator.
3. Setting the process controls to initial settings.
4. Warm up time (if required by process)

### Loading and Positioning the Film

1. Determine the way the film is wound, adhesive inside or outside. This will determine the way it is placed on the unwind shaft. If the adhesive is wound to the inside, the web will be pulled from the bottom of the supply roll. The web path configuration figures show the film in this configuration.
2. Pull the plunger on the shaft support out and rotate it slightly so that it stays in the retracted position. Grasp the shaft and using your thumb lift the shaft locking arm up so that shaft can be pulled out from support.
3. Loosen the set screw in the core support collar using the allen wrench provided. Slide the core support collar off the shaft.
4. Slide the roll of film onto the shaft and up onto the locking core chuck. Slide the core support collar onto the shaft and into the end of the film core.
5. Swing the unwind/windup shaft with film back into the support and rotate the plunger so that it snaps back into position and locks the shaft locking arm into place.
6. Measuring from the sideplates, make sure the film is centered on the shaft. Once the measurements from each end of film to the sideplates are equal, tighten the locking core chuck and core idler down.
7. Repeat this process on any other unwind station.
8. If the film is a pressure sensitive with a release liner, you will need to set up a wind up station. This is done by webbing the film under an idler and separating the film and liner. Once the liner has been separated from the film, it must be routed up and taped to a windup core.
9. The wind up core is loaded by removing the windup tube. Grab the tube and press it back against the spring loaded cup until the near end clears the drive cup. Place core over tube and replace back in machine. Center core on windup tube, use a piece of tape to prevent the core from slipping if required. Keep in mind that the windup cores will rotate the exact same direction as the lower nip roll.
10. Tape the release liner to the core and windup any slack by hand. Feed the film with adhesive around and through the nip opening. **Note: You may require feeder stock to keep the film from sticking to the lower nip roll.**

**Webbing the Laminator**

The term webbing means routing the film through the laminators' idlers and nip rolls and thus creating a web. The easiest way to web the machine up after loading the film is by using a piece of feeder stock. The stock can be anything that is relatively stiff, but still flexible enough to route around the nip roll. A common example would be tag board.

The first step in webbing the machine is to have a planned web path configuration. There are three web path configurations shown in this manual. Encapsulation, Pressure sensitive top and bottom, and pressure sensitive in reverse.

**Encapsulation Process:**

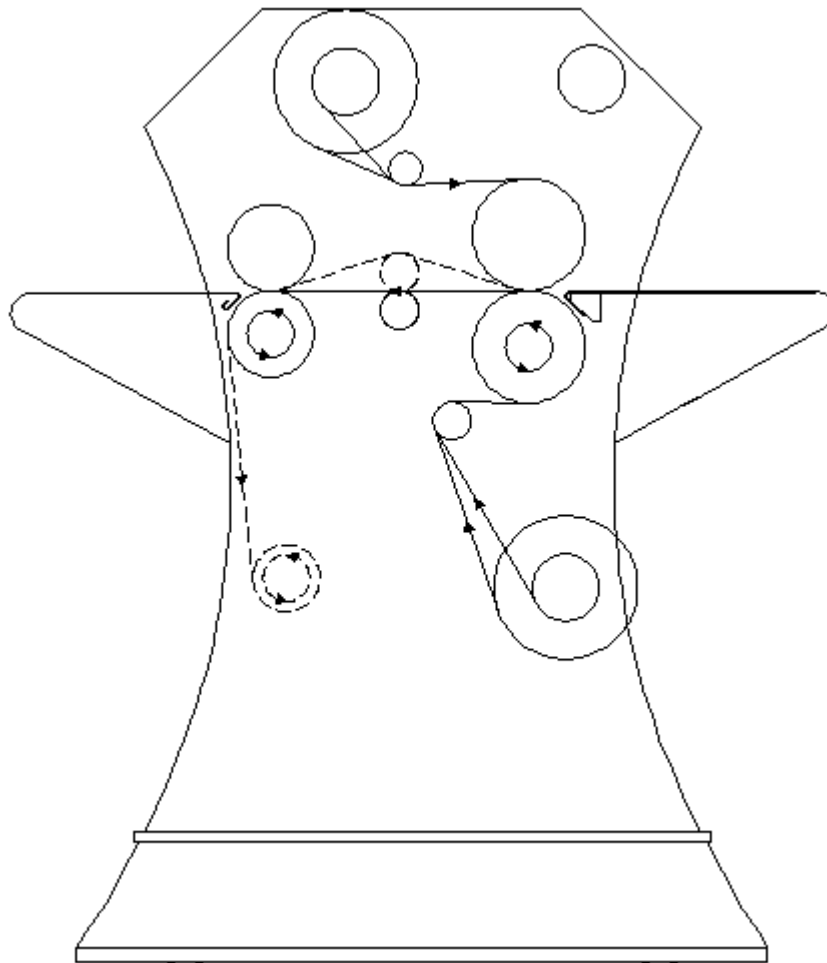

**Figure 7. Encapsulation Process Web Diagram**

## Encapsulation Process

1. Load thermal film on the rear upper and lower unwind stations. Turn the brake to zero.
2. Set temperature on upper and lower nip rolls and allow rolls to balance at temperature.
3. Set the shim wheels to "0" on both the nip rolls and pull rolls.



**CAUTION** *The nip section can pull you into laminator! Do not place fingers into the nip section when the rolls are rotating. It is recommended that operators tie long hair back and not wear neckties, loose clothing and jewelry since they can be caught in the nip section and pull the operator into the machine*

4. Pull the film from the upper rear station down under the idler roller directly behind the nip roll and over the top of the top nip roll. Be sure film is wetting out on the upper roll.
5. Pulling film taut, place lower film against the wet out adhesive on the upper roll. With nip rolls open, push film into the nip opening.
6. Select the forward direction, select a low speed setting with the speed adjust wheel, step on foot switch as the nip rolls are closed. The rolls should pull the film into the nip.
7. Route the film over the chiller roll then through the pull rolls.
8. Pull the web tight and close the pull rolls.
9. If your machine is equipped with optional product windup, route the web down to windup core and tape to core.
10. Using your process sheets, make all the initial settings for your process. Machine is now ready to laminate. Follow the procedures in operation to start your prints and set machine in run mode.

Pressure Sensitive Top and Bottom Process

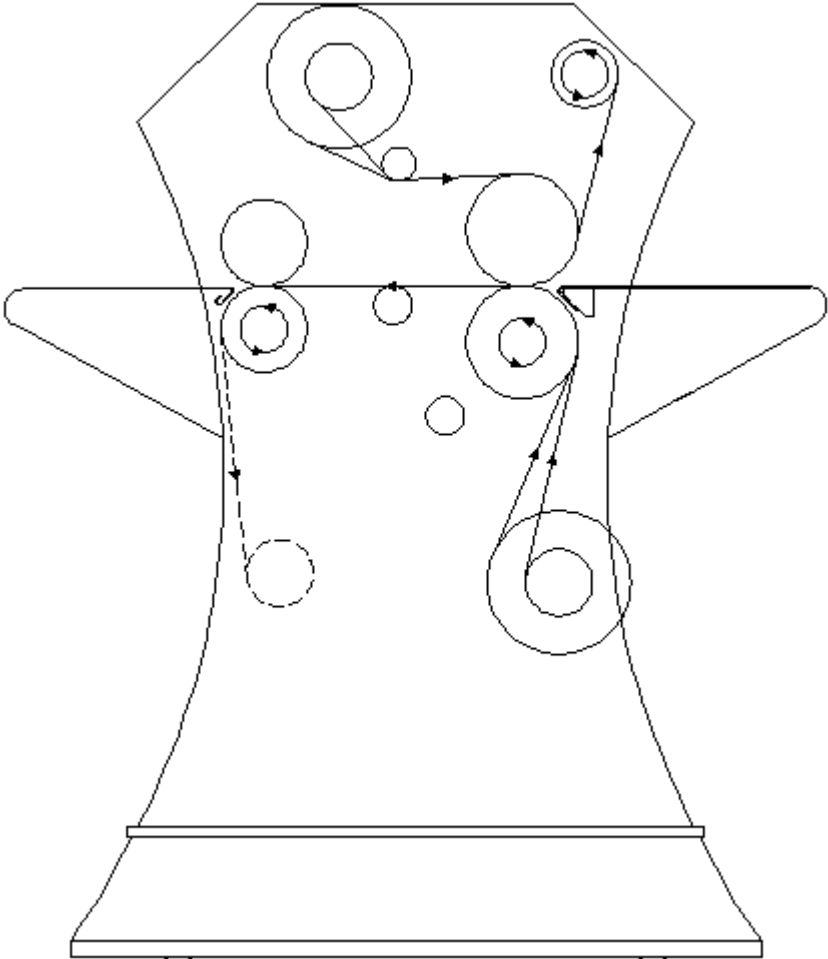

Figure 8. Pressure Sensitive Top and Bottom Process Web Diagram



**Pressure Sensitive Top and Bottom Process**

1. Load film on the rear upper and lower front unwind station. Note that the lower front station cannot be used for a pressure sensitive film with a release liner. Turn the brake to zero.
2. Set temperatures on upper and lower rolls if required by film and allow to balance at temperature.
3. Set the shim wheels to "0" on both the nip rolls and pull rolls, place a piece of feeder stock into the nip rolls with plenty of stock hanging out the front. Close the nip rolls onto the piece of feeder stock.



**WARNING**

*The nip section can pull you into laminator! Do not place fingers into the nip section when the rolls are rotating. It is recommended that operators tie long hair back and not wear neckties, loose clothing and jewelry since they can be caught in the nip section and pull the operator into the machine*

4. Pull the film from the upper rear station down under the idler roller directly behind the nip roll and over the top of the top nip roll. Separate the release liner from the film and stick the film to the feeder stock.
5. Route the release liner up to the front upper windup station. Tape the release liner to the wind up core.
6. Select the forward direction, set the speed adjust wheel to a low setting and move to the rear of the machine.
7. Using the footswitch, run web to pull rolls and close the pull rolls.
8. With web pulled through laminator, you can now lift the infeed table into its locked position.
9. If your machine is equipped with optional product windup, route the web down to windup core and tape to core.
10. Using your process sheets, make all the initial settings for your process. Machine is now ready to laminate. Follow the procedures in operation to start your prints and set machine in run mode.

**Pressure Sensitive Process (Reverse)**

Sometimes mounting processes are required to be run between encapsulation processes. Since the nip rolls will be very warm due to the encapsulation process it is not possible to run a cold mounting process without letting the roll cool down. This could be a very long wait depending on the temperatures used for the encapsulation process. It is possible to run a single side mounting process through the pull rolls in reverse. The web diagram for this process is shown below:

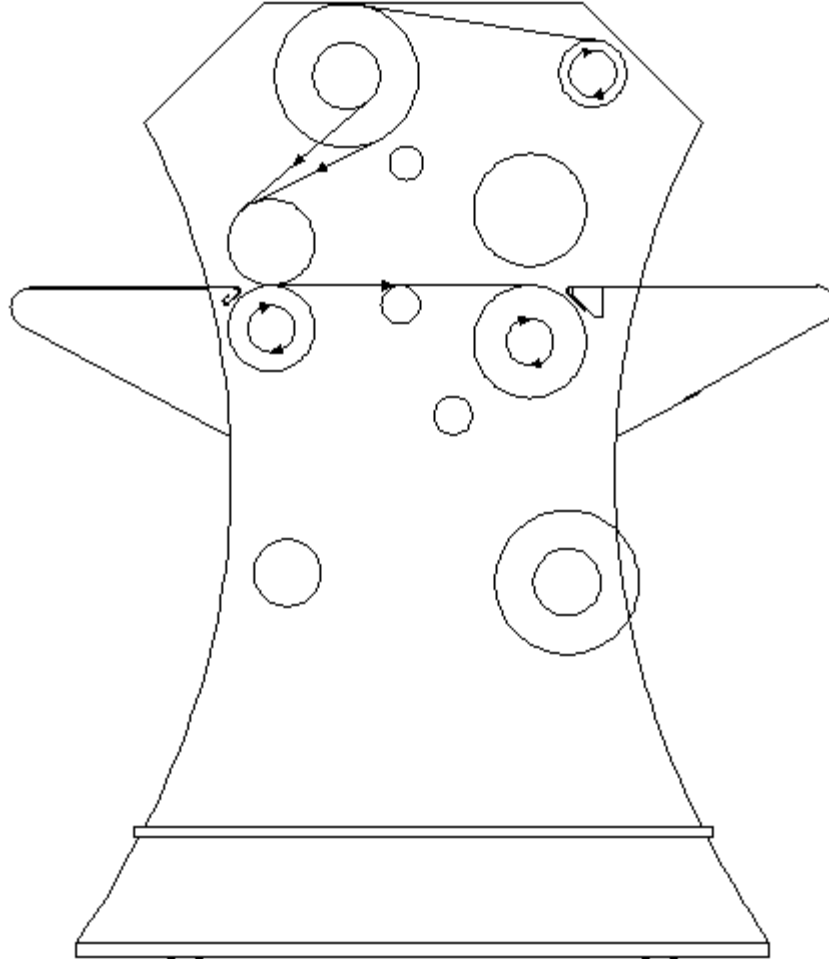

**Figure 9. Pressure Sensitive Process (Reverse)  
Web Diagram**

**Pressure Sensitive Process (Reverse)**

1. Load film on the rear upper unwind station. Turn the brake to zero.
2. Set the shim wheels to "0" on the pull rolls and 1" on the nip rolls, place a piece of feeder stock into the pull rolls with plenty of stock hanging out the front. Close the pull rolls onto the piece of feeder stock.



**WARNING**

*The nip section can pull you into laminator! Do not place fingers into the nip section when the rolls are rotating. It is recommended that operators tie long hair back and not wear neckties, loose clothing and jewelry since they can be caught in the nip section and pull the operator into the machine*

3. Pull the film from the upper rear station down to the top of the upper pull roller, separate the release liner from the film and stick the film to the feeder stock.
4. Route the release liner up and over the film roll to the front upper windup station. Tape the release liner to the wind up core.
5. Select the reverse direction, set the speed adjust wheel to a low setting.
6. Set shim wheel on pull rolls based your substrate you are using.
7. Place substrate into pull rolls and close pull rolls.
8. Using your process sheets, make all the initial settings for your process. Machine is now ready to laminate. Follow the procedures in operation to start your prints and set machine in run mode.
9. Place graphic onto board and run through laminator in reverse. (see operation section for mode sequences)

## Process Output Trouble Shooting

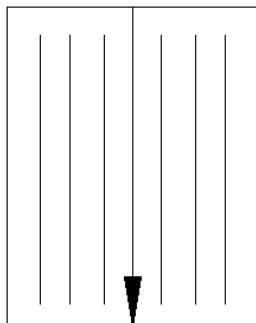

### Straight waves in output

Pull roll creating too much tension → Decrease clutch air pressure

Film not cooling fast enough → Slow feed rate down and turn on cooling system.

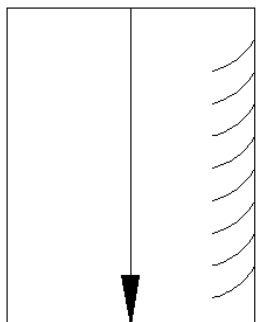

### Waves on one side of output

Nip “zero” setting may be incorrect → Check nip setting and adjust if necessary. Refer to **Zeroing the Nip** in the maintenance section.

Pull roll “zero” setting may be incorrect → Check nip setting and adjust if necessary. Refer to **Zeroing the Nip** in the maintenance section. Pay particular attention to sides opposite the waves.

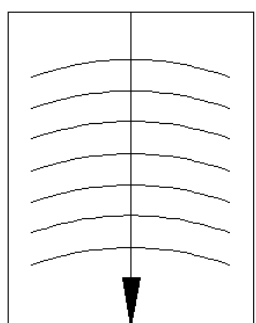

### D-Waves in Product

#### If waves are in the substrate and not film

Substrate problem → Check the substrate moisture content and the substrate tension.

#### If waves are in the film

Low tension between nip & pull roll → Increase air pressure to pull roll clutch.  
Roll pressure settings → Adjust nip and pull roll settings as required.

## Web Breaks

Web breaks caused by excess tension: If the web breaks between the unwind station and the nip, reduce the unwind brake tension. If the web breaks between the laminating opening and the rewind station, reduce the rewind clutch tension.

Web breaks will occur from faulty material. The AGL laminator will not correct this; the material must be replaced.

## Curl in Product

1. Running a hot mount material in cold-mount machine sometimes creates a curl in the finished product.
2. Too much web tension: Reduce unwind brake pressure.
3. Excessive roll pressure: Reduce upper roll pressure.
4. Wrong spacers being used.

### Wrinkles in Product

1. Check the adhesive stock for wrinkles while operating. If wrinkles exist, this is a manufacturing material defect, and must be cut out of the roll. A laminator will not correct material defects.
2. String the web straight and square between the unwind and the windup shafts. If it is not straight and square, the tension will not be even across the web and will cause wrinkling.
3. If the web is loose between the unwind and the drive roll, there is not enough pressure on the unwind brake. Increase the pressure on the unwind brake to correct.
4. If the web is loose between the windup and the drive roll, there is not enough pressure on the windup clutch. Increase the pressure on the windup clutch to correct.
5. If the web gets narrow between the unwind and the drive roll, there is too much pressure on the unwind brake. Decrease the pressure on the unwind brake to correct.
6. Top and bottom laminating rolls may not be parallel. Make sure spacer shims are the same size, then zero the nip. Refer to **Zeroing the Nip** in the maintenance section.

### Poor Lamination

1. All substrate materials must be cleaned and free of dust, dirt, grease, and any other type film.
2. Poor lamination is usually caused by thickness variation in the substrate materials such as plywood, hard board or other such non-precisely made materials. To overcome this, cylinder spacers may have to be removed and materials laminated without the use of cylinder spacers, or the next smaller spacer may be used or special spacer utilized.
3. Material such as Plexiglas or glass sometimes carry a greasy or oily film. These materials may need to be cleaned with a solvent prior to lamination.
4. Poor lamination can be caused by defective material. To correct this, replace defective material with higher quality material.

### Bubbles in Product

1. Visually inspect materials, mounting or overlays for any voids in the adhesive film. If any exist, it cannot be corrected by any laminating machine - that part of the material should be discarded.
2. Low pressure on nip rolls → Increase air pressure to nip rolls.
3. Incorrect shim setting → Adjust shim wheel to correct setting.
4. Nip “zero” setting may be incorrect → Check nip setting and adjust if necessary. Refer to **Zeroing the Nip** in the maintenance section.

### Process Control Charts

In order to consistently output high quality product, the operator must have a definite starting point on the many process variables. This can be achieved by having the operators document system settings when you have achieved acceptable quality output. The process control chart will allow any operator to set the machine up for a given process. Keep in mind that the system variables may require adjusting as the process is being run, but the chart gives an excellent starting point. Factors such as temperature, humidity, changing film roll diameters all affect the process, therefore, operator technique in running the machine is inevitable. There is a blank process control chart located on page 4-10, copy this page as often as needed for new processes.

# PROCESS CONTROL CHART

Process: \_\_\_\_\_  
 Product: \_\_\_\_\_  
 Material Top: \_\_\_\_\_  
 Material Bottom: \_\_\_\_\_  
 Other Material: \_\_\_\_\_  
 Date Settings Documented: \_\_\_\_\_

| <b>Front Control Settings</b> |                              |
|-------------------------------|------------------------------|
| Speed (Ft/min):               | Direction: Forward Reverse   |
| Nip Roll: Up Down             | Shim Dial Setting:           |
| Roll Pressure: (PSI)          | Top Temp. Setting: Deg. F    |
| Top Roll Heater: On Off       | Bottom Temp. Setting: Deg. F |
| Bottom Roll Heater On Off     |                              |
| <b>Rear Control Settings</b>  |                              |
| Pull Roll: Up Down            | Pull Roll Pressure:(PSI)     |
| Shim Dial Setting:            |                              |

Other Instructions: \_\_\_\_\_  
 \_\_\_\_\_  
 \_\_\_\_\_  
 \_\_\_\_\_  
 \_\_\_\_\_  
 \_\_\_\_\_  
 \_\_\_\_\_  
 \_\_\_\_\_  
 \_\_\_\_\_  
 \_\_\_\_\_  
 \_\_\_\_\_

### AGL64 SERIES LAMINATOR ROLL PRESSURE

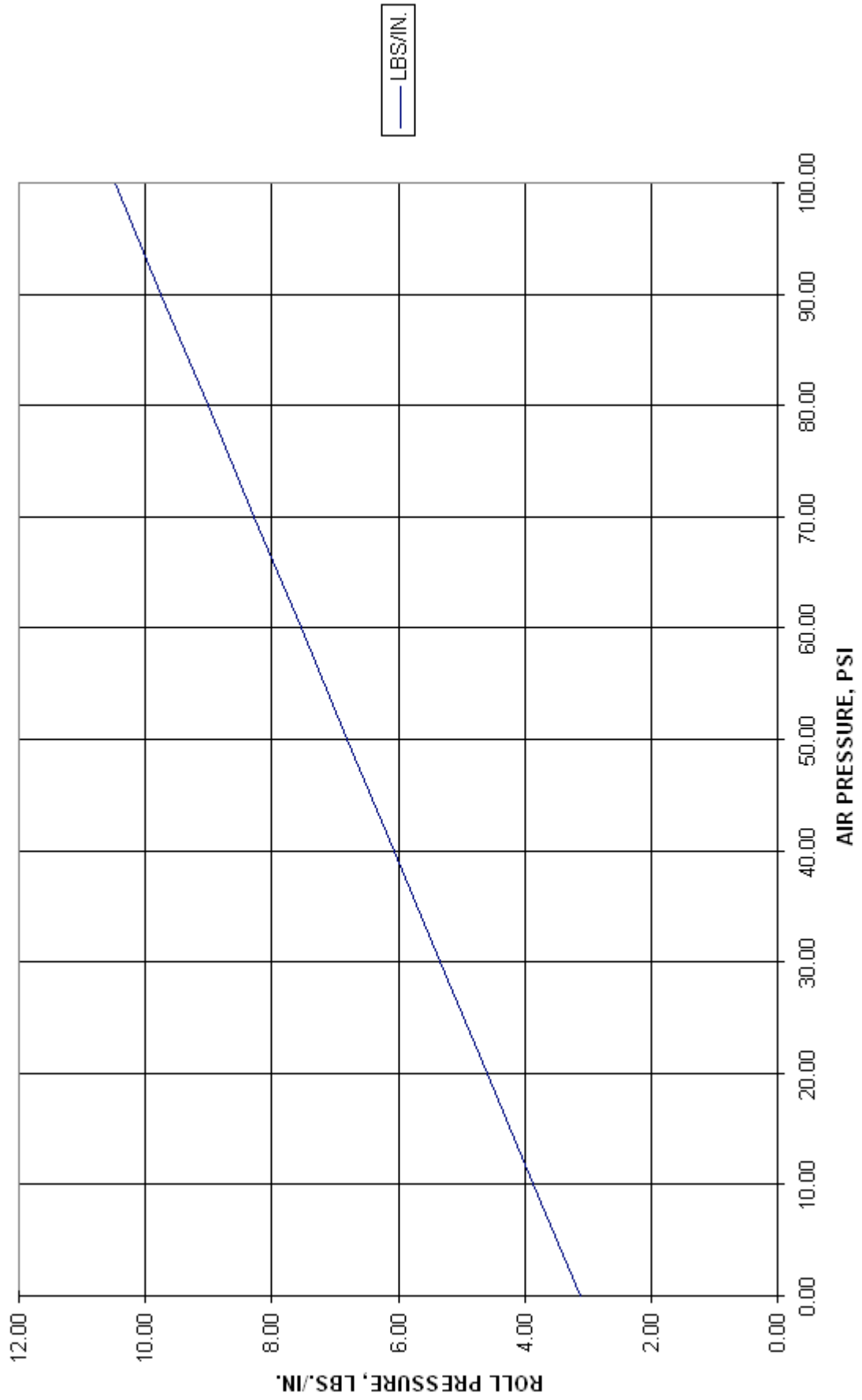

## Maintenance

As a result of years of experience, refined engineering and construction techniques, very little time need be lost to maintenance. However, regular maintenance will keep your laminator operating at its optimum level.



### **WARNING**

***Removing the enclosure covers to work on machine exposes person to electrocution and moving parts hazard. Only trained service personnel should perform maintenance with any guards or covers removed.***

## Nip Roll Section

The most critical adjustment of the nip and pull rolls is the “zero” position. This adjustment makes the top roll parallel to the bottom roll which creates even pressure and pull distribution across the face of the roll. If the rolls are out of adjustment, the machine will not laminate properly. Zeroing the nip is done at the factory before shipment, but should be checked at startup and if laminator is not creating quality output.

### Checking the Nip

1. Place two pieces of thin paper (approximately 1.0” wide by 12.0” long) between the upper pressure roll and the lower roll (about 3.0” from each end).
2. Set the shim dial to the “0” setting and put the upper pressure roll in the down position by activating pressure roll valve.
3. Pull gently on both pieces of paper, if both pieces of paper have the same drag, the nip is fine, if the drag is different, follow the procedure below to correct the setting. The pull rolls are adjusted the same as the nip rolls.

### Zeroing the Nip

1. Loosen the set screws in the cylinder stop.
2. Adjust the cylinder stop clockwise to raise the roll and counter clockwise to lower the roll. (The direction is based on you looking down on the cylinder from above)
3. Check the nip using the 3 steps shown in the **Checking the Nip** section.
4. Once the drag on the pieces of paper has been equalized, tighten the setscrews to secure the cylinder stop.

## Cleaning the Nip Rolls



### **WARNING**

***Cleaning the nip rolls may require the nip rolls to be rotating. Rotate the rolls at a very slow rate to avoid being pulled into the nip section. Do not wear neck ties, loose clothing or hanging jewelry that could be pulled into the nip section.***

The nip rolls should be cleaned as often as necessary, the frequency will vary on the products used and the processes being run. AGL recommends a mild detergent solution or denatured alcohol with a 100% lint free cloth to clean the rolls. Your film manufacturer can recommend solvents that will remove the adhesive from silicone and neoprene rolls without causing damage to the coverings. To facilitate the cleanup process, adhesives should be cleaned from the rolls as soon as possible and while the roll is still warm. A rubber "eraser" has been included in your accessory kit that can be used to clean the adhesive from the warm rolls. Rub the eraser over the adhesive with the rolls turning very slowly. The cloth and alcohol can be used to remove the residue.



### **CAUTION**

***Use of incorrect solvents on your nip and pull rolls can cause irreparable damage to the coverings. Advanced Grieg Laminators, Inc. is not responsible for damage to roll coverings caused by these solvents.***



### Roller open and close rate

The rollers must open and close evenly to prevent excessive wear on the cylinders and bearings. This rate is set at the factory, but can be adjusted in the field. Follow the procedure below to adjust either the pull rolls or nip rolls.



### **WARNING**

***Maintenance that requires working on the machine while power and air are connected poses and imminent danger of electrocution or extremities being caught in rotating parts. Only qualified personnel should work on a machine in this state***

1. There are flow control fittings on both cylinders, but the fittings on the left hand cylinders will require most of the adjusting.
2. To increase the rate, turn the adjustment screw counter clockwise, to decrease the rate turn the adjustment screw clockwise. The upper fitting controls the "Open" rate, and the lower fitting controls the "Close" rate. Do not rotate the screw more than ½ turn at a time.
3. Adjust the open rate until the rolls open correctly, then proceed with the close rate.
4. Lock the adjustment screw in place with the jam nut. Be careful not to turn the adjustment screw as you tighten the nut.
5. Replace enclosure covers.

### Lubrication

The high temp grease that is packed into the lower nip roll bearings will begin to pass by the seal as the machine is used in high temperature applications. The frequency of high heat processes will determine the frequency of adding grease to the bearings. Inspect the nip roll bearings at least weekly for grease outside the seals, regrease as necessary. The lower pull roll bearings should be checked for grease leakage after 3 months of use and then every 6 months from there on. The grease is a standard lithium based grease. The grease should be added slowly with the shaft turning until a slight bead forms at the seal.

Manufacturer lubrication recommendations:

High Temp Bearings: Dow Corning 44

Std. Temp Bearings: Shell Alvania Grease No. 3

When the bearings are being greased, the bearing gibs should also receive a coating of lithium grease.

The chain should be lubricated as needed with a Lubriplate spray chain lubricant. The tension in the chain should be checked at 6 months and tightened to take up any stretching that may have occurred, and then inspected yearly from that point on.

## Warranty and Conditions

AGL warrants all models of the laminator's product line manufactured to be free from defects in workmanship and materials for a period of one year with the exception of operator caused damage, or surface abrasions to the laminating rolls or other obvious caused damage. Compression set in silicone covered nip rolls can occur when a thicker material combination is run in the same lateral position through the nip roll on a consistent basis. This will permanently damage the silicone cover. Randomizing the lateral position of the process through the nip rolls for continuous production runs will maximize the life of the silicone covering. It is the sole responsibility of the end user to periodically shift the process from one side to the other to prevent compression set from happening. Compression set in the silicone coverings is not covered under the factory warranty. The warranty period will commence on the date it ships from AGL.

This warranty does not apply to any equipment which after delivery has been subject to abuse, accident or alterations by anyone other than persons authorized by AGL.

Component parts such as controls, motors, heating elements, air cylinders, rubber coverings, etc. which are incorporated into the design and manufacture of our laminators are purchased from reputable manufacturers and suppliers and, as such carry their respective warranties. Failure of any components purchased by AGL and incorporated in the laminators carry supplier warranty and to insure proper credit all parts that should fail must be returned freight prepaid for evaluation **LABOR AND ALL RELATED COSTS TO REPLACE THE DEFECTIVE PART WILL BE BORNE ENTIRELY BY THE END USER.** AGL assumes the responsibility of incorporating these various component parts into the fabrication of the laminator and warrants that this will be done in a suitable and workable manner.

AGL offers no warranty for the laminated product and/or process that the machine produces and as such will not be liable for any special, indirect or consequential damages.

**NO OTHER WARRANTY IS EXPRESSED OR IMPLIED INCLUDING WARRANTIES OF MERCHANTABILITY AND FITNESS FOR ANY PARTICULAR PURPOSE. AGL is not liable for incidental or consequential damage such as, but not limited to, lost profits, loss of use of other equipment or increases in operating costs or expenses.**

---

# Bill Of Material

---

**Part #:** AGL-64-K4966

**Appl #:**

**Assy #:**

**BOM Rev:** B

**Model #:**

**Rev:**

**Rev:**

**Date:** 4/24/2003

**Description:** MASTER BILL OF MATERIALS, ENCORE DHR (STD)

---

| Item: | Part #:        | Description:                                 | Qty: |
|-------|----------------|--|------|
| 1     | AGL-64-K4803-1 | MAIN MACHINE FRAME, ENCORE SERIES            | 1    |
| 2     | AGL-64-K4677   | NIP ROLL ASSEMBLY                            | 1    |
| 3     | AGL-64-K4678   | PULL ROLL ASSEMBLY                           | 1    |
| 4     | AGL-64-K4687-4 | DRIVE ASSEMBLY, ENCORE DHR                   | 1    |
| 5     | AGL-64-K4760-2 | UNWIND ASSEMBLY, NO DISPLAY, ENCORE          | 1    |
| 6     | AGL-64-K4731-1 | LINER WINDUP ASSEMBLY, ENCORE                | 1    |
| 7     | AGL-64-K4748   | IDLER ASSEMBLY                               | 1    |
| 8     | AGL-64-K4972   | INFEED TABLE, REMOVABLE, ENCORE SERIES       | 1    |
| 9     | AGL-64-K4974   | OUTFEED TABLE, REMOVABLE, ENCORE SERIES      | 1    |
| 10    | AGL-64-K4721-1 | PNEUMATIC ASSEMBLY, ENCORE MAXIM & DHR       | 1    |
| 11    | AGL-64-K4986   | BASE ELECTRICAL ASSY, ENCORE DHR             | 1    |
| 12    | AGL-64-K4824-1 | MOVABLE IDLER ASSEMBLY, DHR                  | 1    |
| 13    | AGL-64-K4999   | DECAL PACKAGE, BASE ENCORE DHR (BLUE)        | 1    |
| 14    | AGL-XX-K2660   | ACCESSORIES KIT, 44/4400/64 SERIES/6400/6450 | 1    |
| 15    | AGL-64-K5033   | INFEED HOLD DOWN ASSEMBLY, ENCORE SERIES     | 1    |

---

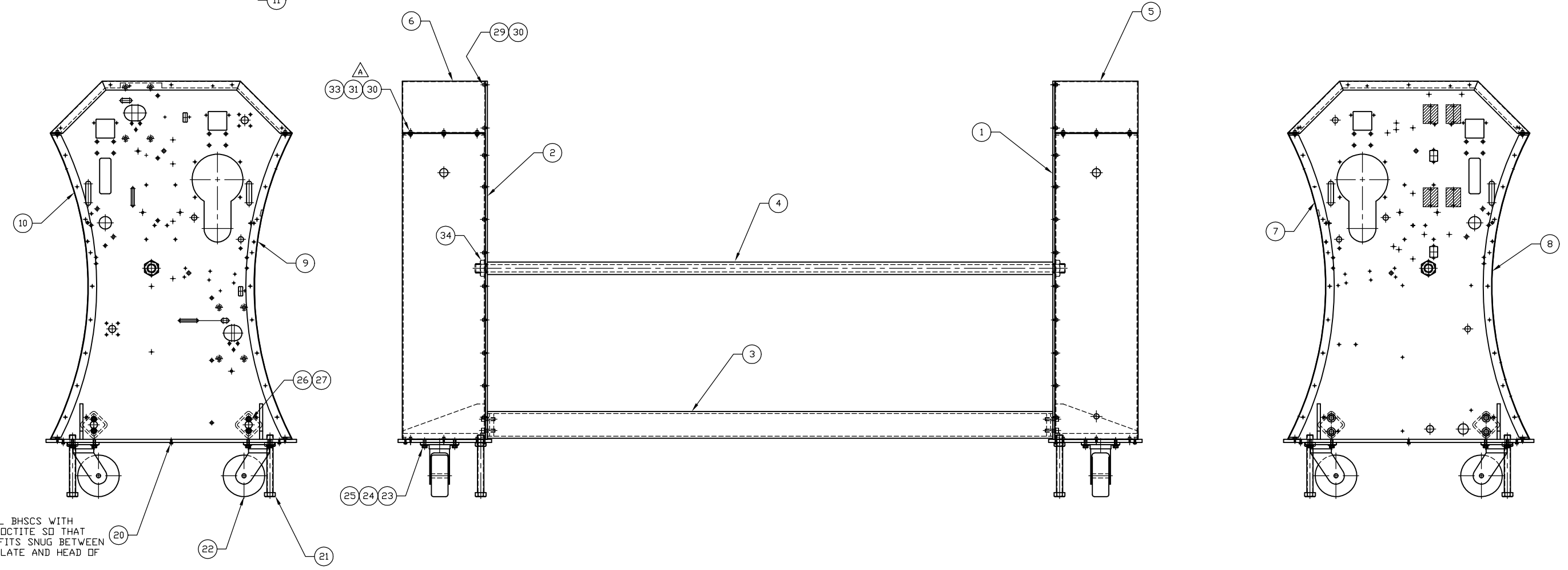
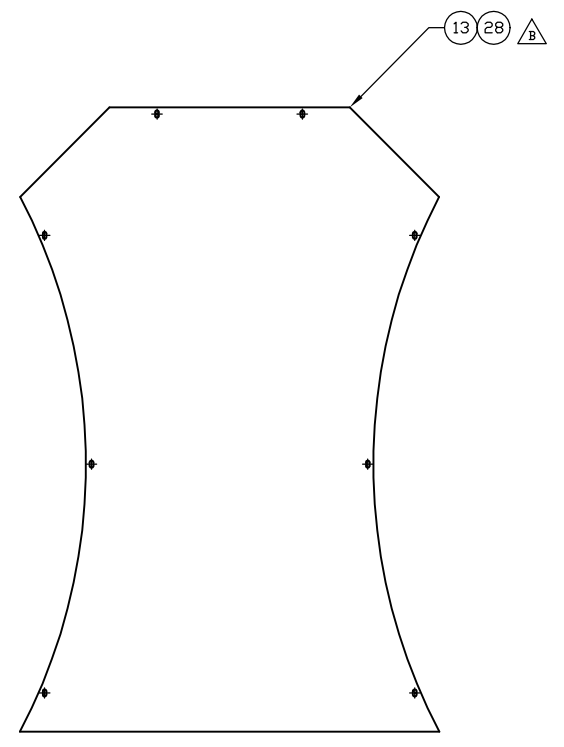
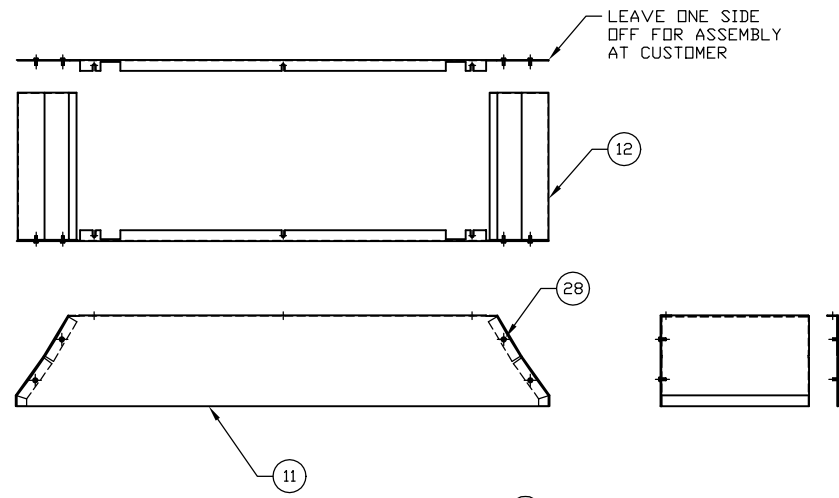

INSTALL BHSCS WITH BLUE LOCTITE SO THAT SKIRT FITS SNUG BETWEEN BASE PLATE AND HEAD OF SCREW

|                                |  |     |  |   |  |
|--------------------------------|--|-----|--|---|--|
| <b>BREAK ALL SHARP EDGES</b>   |  |     |  |  Advanced Greig Laminators, Inc.<br>801 Burton Blvd.<br>DeForest, WI 53532 |  |
| <b>DO NOT SCALE DWG.</b>       |  |     |  | MATERIAL: AGLK4803-1  |  |
| UNLESS OTHERWISE SPECIFIED     |  |     |  | FINISH:   |  |
| 0.00 +/-0.015                  |  |     |  | SCALE: 1/6" = 1"  |  |
| 0.000 +/-0.005                 |  |     |  | DATE: 4-7-03  |  |
| ANGLES +/- .5°                 |  |     |  | DWG. NO. AGL-64-D4802-1   |  |
| JDB NO. QTY. DWG. BY. CHK. BY. |  | GFT |  | REV. B  |  |

|          |                          |          |      |     |
|----------|--------------------------|----------|------|-----|
| B        | REMOVED 8 FASTENERS (28) | 11-7-07  | GFT  |     |
| A        | REMOVED #32              | 11-29-04 | GFT  |     |
| REV. NO. | DESCRIPTION              | DATE     | INT. | ECN |

# Bill Of Material

|   |                |                           |                       |
|---|----------------|---------------------------|-----------------------|
| <b>Part #:</b> AGL-64-K4803-1                         | <b>Appl #:</b> | <b>Assy #:</b> AGLD4802-1 | <b>BOM Rev:</b> D     |
| <b>Model #:</b>                                       | <b>Rev:</b>    | <b>Rev:</b> B             | <b>Date:</b> 4/7/2003 |
| <b>Description:</b> MAIN MACHINE FRAME, ENCORE SERIES |                |                           |                       |

| Item: | Part #:         | Description:  | Qty: |
|-------|-----------------|---|------|
| 1     | AGL-XX-D4798-1  | RH. SIDEPLATE WELDMENT, ENCORE SERIES                 | 1    |
| 2     | AGL-XX-D4797-1  | LH. SIDEPLATE WELDMENT, ENCORE SERIES                 | 1    |
| 3     | AGL-64-B4801    | LOWER TIE BAR   | 2    |
| 4     | AGL-64-B0010-03 | CROSS TUBE, WHITE                                     | 1    |
| 5     | AGL-XX-D4799    | RH. TOP WRAP  | 1    |
| 6     | AGL-XX-D4800    | LH. TOP WRAP  | 1    |
| 7     | AGL-XX-C4937    | WRAP WLD, RIGHT FRONT                                 | 1    |
| 8     | AGL-XX-C4938    | WRAP WLD, RIGHT REAR                                  | 1    |
| 9     | AGL-XX-C4939    | WRAP WLD, LEFT FRONT                                  | 1    |
| 10    | AGL-XX-C4940    | WRAP WLD, LEFT REAR                                   | 1    |
| 11    | AGL-XX-C4789    | SKIRT, SIDE   | 4    |
| 12    | AGL-XX-B4790    | SKIRT, END  | 4    |
| 13    | AGL-XX-C4788-1  | COVER, ENCORE SERIES                                  | 2    |
| 20    | 000071-03       | BHSCS, #10-32UNF, 3/8 LG, BLACK                       | 12   |
| 21    | 000358-36       | HHCS, 3/4-10UNC, 7 LG, ZINC                           | 4    |
| 22    | 001451          | CASTER, SWIVEL, 5 DIA 900 LBS.                        | 4    |
| 23    | 000340-06       | HHCS, 5/16-18UNC, 3/4 LG, ZINC                        | 16   |
| 24    | 000207-07       | WASHER, FLAT, SAE, 5/16 DIA, 11/16 OD, 11/32 ID, ZINC | 16   |
| 25    | 000493-07       | WASHER, LOCK, 5/16 DIA, SPLIT, ZINC                   | 16   |
| 26    | 000343-12       | HHCS, 3/8-16UNC, 1-1/2 LG, ZINC                       | 8    |
| 27    | 000493-08       | WASHER, LOCK, 3/8 DIA, SPLIT, ZINC                    | 8    |
| 28    | 000055-03       | BHSCS, #8-32UNC, 3/8 LG, BLACK                        | 40   |
| 29    | 000035-03       | SHCS, #10-32UNF, 3/8 LG, BLACK                        | 34   |
| 30    | 000207-04       | WASHER, FLAT, SAE, #10 DIA, 1/2 OD, 7/32 ID, ZINC     | 58   |
| 31    | 000334-04       | HHCS, #10-24UNC, 1/2 LG, ZINC                         | 12   |
| 33    | 001211-04       | NUT, K-LOCK, #10-24UNC, ZINC                          | 12   |
| 34    | 000198-15       | NUT, HEX, JAM, 1-1/8-12UNF, ZINC                      | 4    |

NOTE:  
 FITTINGS ON CYLINDER ON THE LH SIDE MUST  
 HAVE FITTINGS TOWARDS THE FRONT OF THE  
 MACHINE.

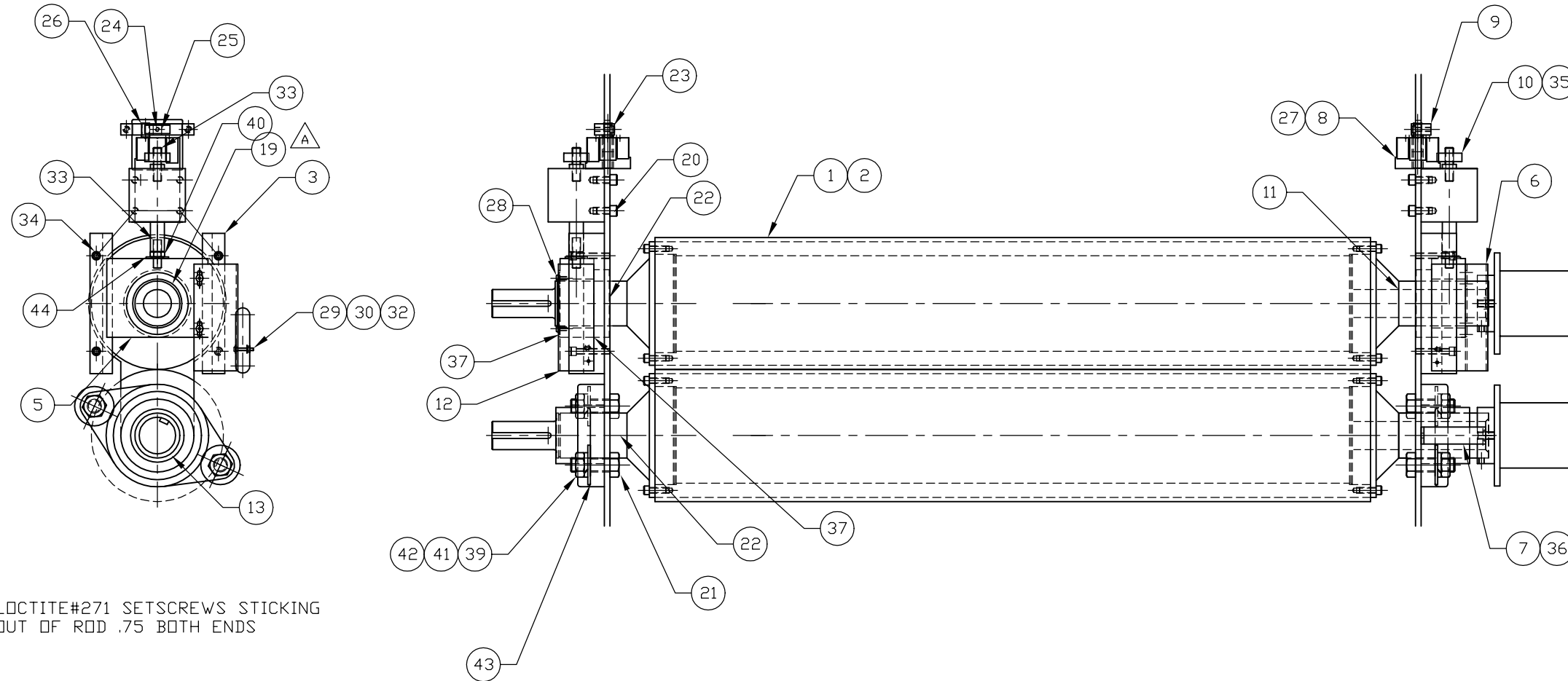

LOCTITE#271 SETSCREWS STICKING  
 OUT OF ROD .75 BOTH ENDS

| REV NO. | DESCRIPTION           | DATE     | INT. | ECN | BREAK ALL SHARP EDGES<br>DO NOT SCALE DWG.                                      |                    |      |   |  Advanced Greig Laminators, Inc.<br>801 Burton Blvd.<br>DeForest, WI 53532 |                                 | REV.      |
|---------|-----------------------|----------|------|-----|---|--------------------|------|---|---|---------------------------------|-----------|
| C       | #20 WAS BHSCS         | 1-12-04  | GFT  |     | UNLESS OTHERWISE SPECIFIED<br>0.00 +/-0.015<br>0.000 +/-0.005<br>ANGLES +/- .5° | MAT'L:<br>AGLK4677 |      | NIP ROLL ASSEMBLY<br>ENCORE MAXIM & DHR |   | SCALE: 1/4 = 1<br>DATE: 9-20-02 | REV.<br>C |
| B       | #21 WAS SHCS          | 10-24-03 | GFT  |     |   | FINISH:            |      |   |   |                                 |           |
| A       | REMOVED #13 ADDED #19 | 7-11-03  | GFT  |     |   | JOB NO.            | QTY. | DWG. BY.                                | CHK BY.   | DWG. NO.                        |           |
|         |                       |          |      |     |   |                    | GFT  |   | AGL-64-C4675  |                                 |           |

# Bill Of Material

**Part #:** AGL-64-K4677

**Appl #:**

**Assy #:** AGLC4675

**BOM Rev:** E

**Model #:**

**Rev:**

**Rev:** C

**Date:** 12/23/2002

**Description:** NIP ROLL ASSEMBLY

| Item: | Part #:        | Description:                                     | Qty: |
|-------|----------------|--|------|
| 1     | AGL-64-D1113   | NIP ROLL SUB ASSY, AGL 64                        | 2    |
| 2     | AGL-64-C1116   | HEATING ELEMENT, AGL 64                          | 2    |
| 3     | AGL-64-B1117   | BEARING GIB                                      | 4    |
| 5     | AGL-XX-B4674   | HOUSING, BEARING, UPPER ROLL                     | 2    |
| 6     | AGL-64-B1121-1 | RH. PHOTOEYE MTG. BRKT, AGL64                    | 1    |
| 7     | AGL-XX-B1070   | BRACKET, SLIP RING STOP                          | 1    |
| 8     | AGL-64-B0015   | SHIM WHEEL                                       | 2    |
| 9     | AGL-XX-B4707   | SHIM WHEEL SUPPORT                               | 2    |
| 10    | AGL-64-B0913-1 | STOP, CYLINDER, TAPPED                           | 2    |
| 11    | AGL-64-B1155   | JOURNAL PLUG, AGL 64                             | 2    |
| 12    | AGL-64-B4325   | LH. PHOTOEYE MTG. BRKT, AGL64                    | 1    |
| 19    | 012411-24      | BEARING, 2.00 ID. x 2.188 OD. x 1.50 LG.         | 2    |
| 20    | 000011-06      | SHCS, 5/16-18UNC, 3/4 LG, BLACK                  | 8    |
| 21    | 012372-14      | HHCS, 5/8-11UNC, 1-3/4 LG, PLAIN BLACK FINISH    | 4    |
| 22    | 000417-32      | COLLAR, SHAFT, 2-PIECE, 2 DIA BORE, 11/16 WIDE   | 1    |
| 23    | 000007-06      | SHCS, #10-24UNC, 3/4 LG, BLACK                   | 4    |
| 24    | 000129-06      | SSS, CUP PT, #10-24UNC, 3/8 LG, BLACK            | 2    |
| 25    | 000289-16      | PIN, DOWEL, 3/8 DIA, 2 LG                        | 2    |
| 26    | 001392-15      | PLUNGER, SPRING, LEP, 3/8-16UNC, 5/8 LG          | 2    |
| 27    | 000732-06      | BUSHING, BRONZE, 3/8 ID, 1/2 OD, 3/4 LG          | 4    |
| 28    | 000055-03      | BHSCS, #8-32UNC, 3/8 LG, BLACK                   | 2    |
| 29    | 000553-08      | PHMS, SLOTTED, #4-40UNC, 1 LG, ZINC              | 2    |
| 30    | 000207-01      | WASHER, FLAT, SAE, #4 DIA, 5/16 OD, 1/8 ID, ZINC | 4    |
| 31    | 000493-01      | WASHER, LOCK, #4 DIA, SPLIT, ZINC                | 2    |
| 32    | 000201-01      | NUT, HEX, #4-40UNC, ZINC                         | 2    |
| 33    | 000161-24      | SSS, CUP PT, 3/8-24UNF, 1-1/2 LG, BLACK          | 4    |
| 34    | 000009-12      | SHCS, 1/4-20UNC, 1-1/2 LG, BLACK                 | 8    |
| 35    | 012378-04      | SSS, BRASS TIP, 1/4-20UNC, 1/4" LG.              | 4    |

Part #: AGL-64-K4677

Appl #:

Assy #: AGLC4675

BOM Rev: E

Model #:

Rev:

Rev: C

Date: 12/23/2002

Description: NIP ROLL ASSEMBLY

| Item: | Part #:    | Description:   | Qty: |
|-------|------------|--|------|
| 36    | 000035-03  | SHCS, #10-32UNF, 3/8 LG, BLACK                               | 2    |
| 37    | 012396-32  | BEARING, THRUST, WASHER, 2 DIA BORE, .03 THICK               | 2    |
| 38    | 000928-128 | RING, RETAINING, EXT, 2 DIA                                  | 2    |
| 39    | 000201-11  | NUT, HEX, 5/8-11UNC, ZINC                                    | 4    |
| 40    | 000198-07  | NUT, HEX, JAM, 3/8-24UNF, ZINC                               | 2    |
| 41    | 000207-12  | WASHER, FLAT, SAE, 5/8 DIA, 1-5/16 OD, 21/32 ID, ZINC        | 4    |
| 42    | 000493-12  | WASHER, LOCK, 5/8 DIA, SPLIT, ZINC                           | 4    |
| 43    | 012108-32  | BEARING, FLANGE, 2-BOLT, 2 DIA BORE, HIGH TEMP               | 2    |
| 44    | 012416-07  | WASHER, FLAT, SAE, 5/16 DIA, 11/16 OD, 11/32 ID, BLACK OXIDE | 2    |



SET SCREWS TO EXTEND OUT OF CYLINDER .75 INCHES

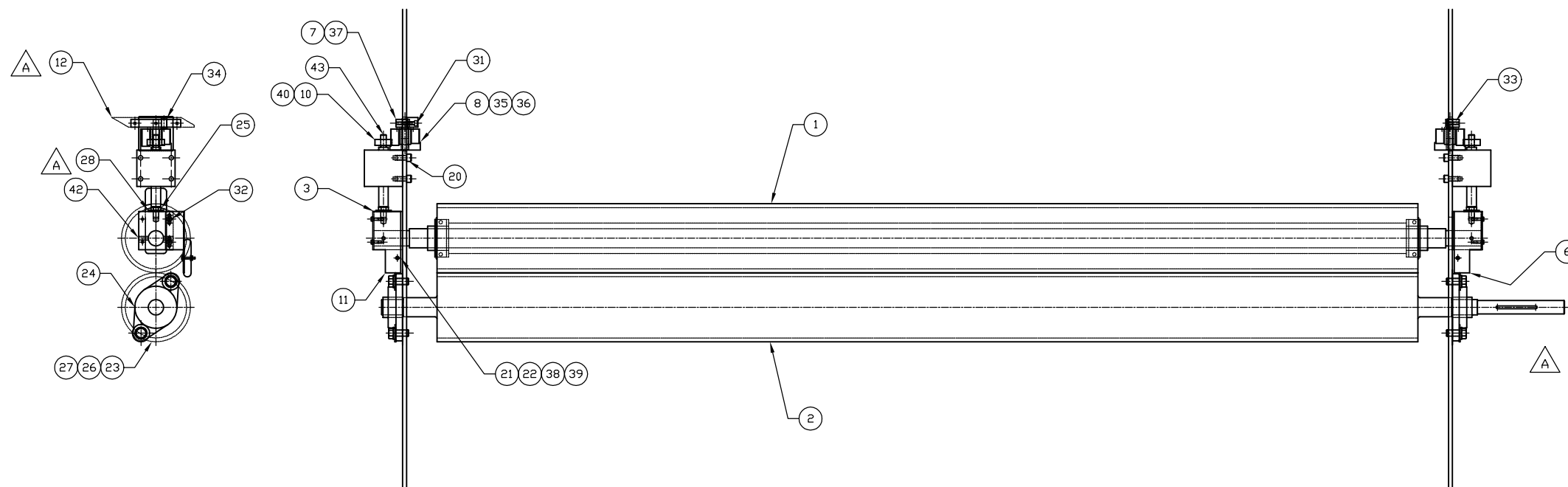

|         |                                   |         |      |     |   |                                     |   |                                 |                                 |
|---------|-----------------------------------|---------|------|-----|---|-------------------------------------|---|---------------------------------|---------------------------------|
|         |                                   |         |      |     | <b>BREAK ALL SHARP EDGES</b>  |                                     |  Advanced Greig Laminators, Inc.<br>801 Burton Blvd.<br>DeForest, WI 53532 |                                 |                                 |
|         |                                   |         |      |     | <b>DO NOT SCALE DWG.</b>  |                                     |   |                                 |                                 |
| C       | #20 WAS BHSCS                     | 1-12-04 | GFT  |     | UNLESS OTHERWISE SPECIFIED<br>0.00 +/-0.015<br>0.000 +/-0.005<br>ANGLES +/--.5° | MAT'L:<br>AGLK4678                  |   | <b>PULL ROLL ASSEMBLY</b>       |                                 |
| B       | ADDED #43, ADDED NOTE             | 8-1-03  | GFT  |     |   | FINISH:                             |   |                                 |                                 |
| A       | ADDED #12, REMOVED CLUTCH,EYEBOLT | 3-11-03 | GFT  |     |   | JOB NO. QTY. DWG. BY. CHK BY<br>GFT |   | SCALE: 1/6 = 1<br>DATE: 9-23-02 | DWG. NO.<br><b>AGL-64-C4679</b> |
| REV NO. | DESCRIPTION                       | DATE    | INT. | ECN |   |                                     |   |                                 |                                 |

# Bill Of Material

**Part #:** AGL-64-K4678

**Appl #:**

**Assy #:** AGLC4679

**BOM Rev:** E

**Model #:**

**Rev:**

**Rev:** C

**Date:** 9/23/2002

**Description:** PULL ROLL ASSEMBLY

| Item: | Part #:        | Description:  | Qty: |
|-------|----------------|---|------|
| 1     | AGL-64-B0842   | UPPER PULL ROLL SUB ASSY                              | 1    |
| 2     | AGL-64-B0018   | LOWER PULL ROLL                                       | 1    |
| 3     | AGL-64-B2244-1 | PULL ROLL GUIDE BLOCK, AGL64R/64i                     | 2    |
| 5     | 001317-16      | KEY, 0.188 SQ, 2.00 LG, CRS                           | 1    |
| 6     | AGL-64-B4388-1 | SENSOR BRACKET, LH. AGL64R/64i                        | 1    |
| 7     | AGL-XX-B4707   | SHIM WHEEL SUPPORT                                    | 2    |
| 8     | AGL-64-B0015   | SHIM WHEEL  | 2    |
| 10    | AGL-64-B0913-1 | STOP, CYLINDER, TAPPED                                | 2    |
| 11    | AGL-64-B4388-2 | SENSOR BRACKET, RH. AGL64R/64i                        | 1    |
| 12    | AGL-XX-B4859   | UNWIND RAMP   | 1    |
| 20    | 000011-05      | SHCS, 5/16-18UNC, 5/8 LG, BLACK                       | 8    |
| 21    | 000573-06      | PHMS, PHILLIPS, #4-40UNC, 3/4 LG, ZINC                | 2    |
| 22    | 000207-01      | WASHER, FLAT, SAE, #4 DIA, 5/16 OD, 1/8 ID, ZINC      | 4    |
| 23    | 000346-07      | HHCS, 7/16-14UNC, 7/8 LG, ZINC                        | 4    |
| 24    | 012413-16      | BEARING, FLANGE, 2-BOLT, 1.00 DIA BORE                | 2    |
| 25    | 000198-07      | NUT, HEX, JAM, 3/8-24UNF, ZINC                        | 2    |
| 26    | 000493-09      | WASHER, LOCK, 7/16 DIA, SPLIT, ZINC                   | 4    |
| 27    | 000207-09      | WASHER, FLAT, SAE, 7/16 DIA, 59/64 OD, 15/32 ID, ZINC | 4    |
| 28    | 001350-07      | WASHER, FLAT, USS, 5/16 DIA, 7/8 OD, 3/8 ID, ZINC     | 2    |
| 31    | 000007-10      | SHCS, #10-24UNC, 1-1/4 LG, BLACK                      | 2    |
| 32    | 000055-03      | BHSCS, #8-32UNC, 3/8 LG, BLACK                        | 4    |
| 33    | 000057-05      | BHSCS, #10-24UNC, 5/8 LG, BLACK                       | 2    |
| 34    | 001392-15      | PLUNGER, SPRING, LEP, 3/8-16UNC, 5/8 LG               | 2    |
| 35    | 000732-06      | BUSHING, BRONZE, 3/8 ID, 1/2 OD, 3/4 LG               | 4    |
| 36    | 000289-16      | PIN, DOWEL, 3/8 DIA, 2 LG                             | 2    |
| 37    | 000129-06      | SSS, CUP PT, #10-24UNC, 3/8 LG, BLACK                 | 2    |
| 38    | 000201-01      | NUT, HEX, #4-40UNC, ZINC                              | 2    |
| 39    | 000494-01      | WASHER, LOCK, #4 DIA, INT STAR, ZINC                  | 2    |

**Part #:** AGL-64-K4678

**Appl #:**

**Assy #:** AGLC4679

**BOM Rev:** E

**Model #:**

**Rev:**

**Rev:** C

**Date:** 9/23/2002

**Description:** PULL ROLL ASSEMBLY

---

| <b>Item:</b> | <b>Part #:</b> | <b>Description:</b>                     | <b>Qty:</b> |
|--------------|----------------|---|-------------|
| 40           | 012378-04      | SSS, BRASS TIP, 1/4-20UNC, 1/4" LG.     | 4           |
| 42           | 000131-08      | SSS, CUP PT, 1/4-20UNC, 1/2 LG, BLACK   | 2           |
| 43           | 000161-24      | SSS, CUP PT, 3/8-24UNF, 1-1/2 LG, BLACK | 4           |

---

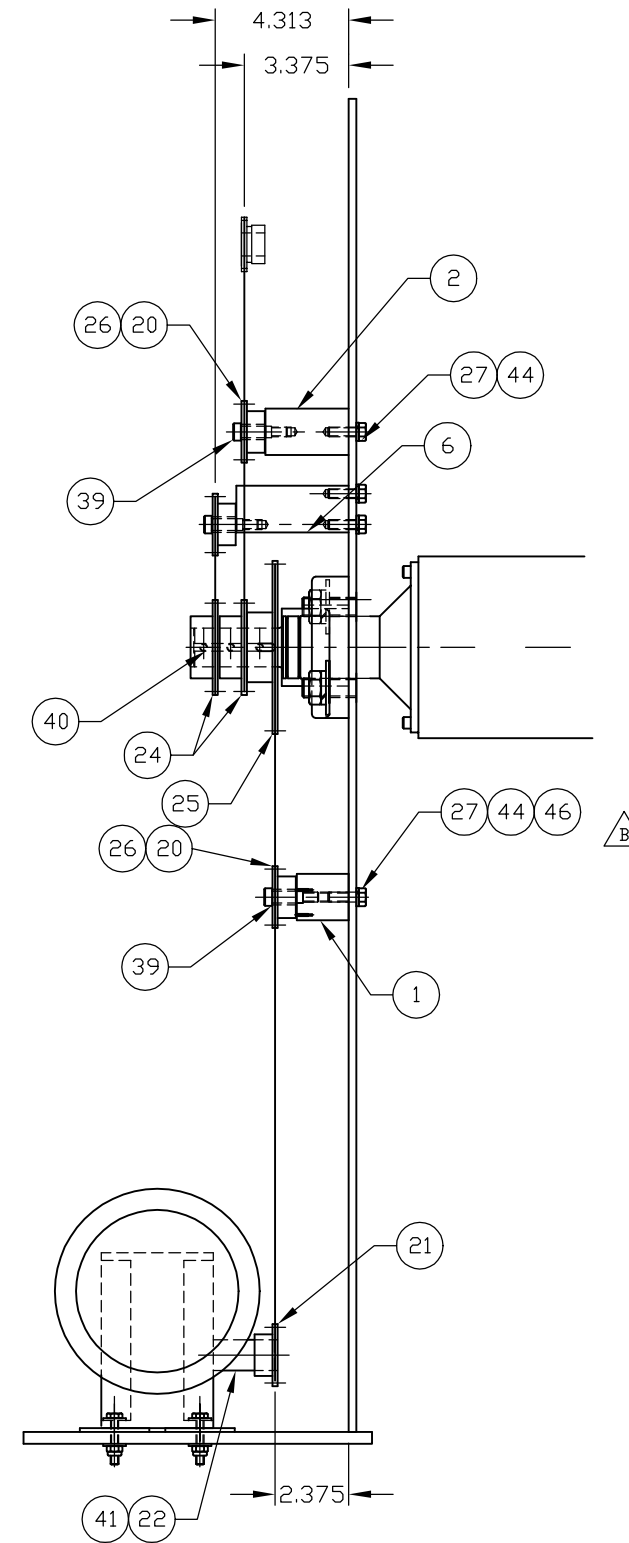
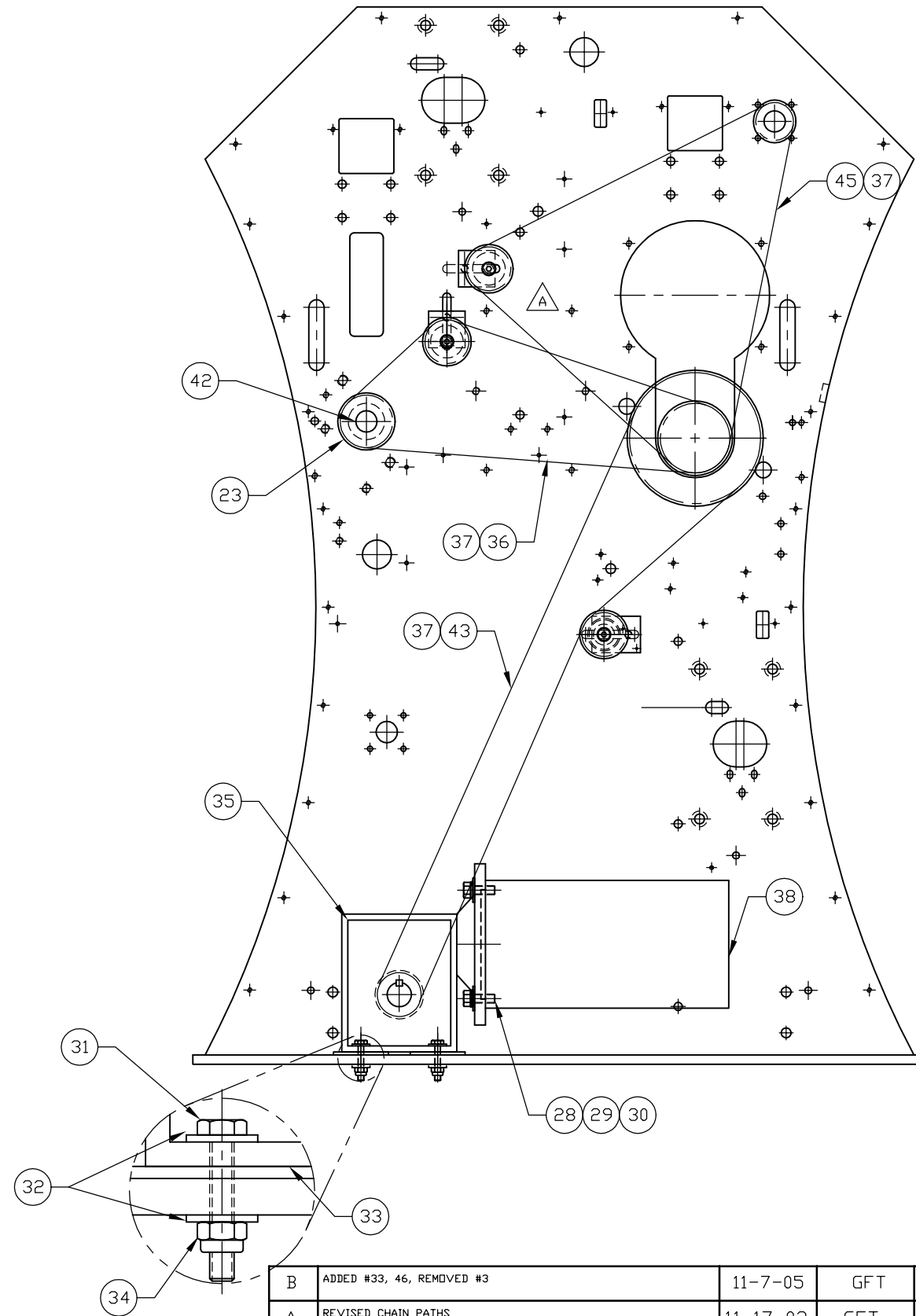

|         |                           |          |      |      |
|---------|---------------------------|----------|------|------|
| B       | ADDED #33, 46, REMOVED #3 | 11-7-05  | GFT  |      |
| A       | REVISED CHAIN PATHS       | 11-17-03 | GFT  | 2106 |
| REV NO. | DESCRIPTION               | DATE     | INT. | ECN  |

|                              |                   |      |         |
|------------------------------|-------------------|------|---------|
| <b>BREAK ALL SHARP EDGES</b> |                   |      |         |
| <b>DO NOT SCALE DWG.</b>     |                   |      |         |
| UNLESS OTHERWISE SPECIFIED   | MAT'L: AGLK4687-4 |      |         |
| 0.00 +/-0.015                | FINISH:           |      |         |
| 0.000 +/-0.005               | JOB NO.           | QTY. | DWG. BY |
| ANGLES +/-5°                 |                   |      | CHK BY  |
|                              |                   |      | GFT     |

**AGL** Advanced Greig Laminators, Inc.  
801 Burton Blvd.  
DeForest, WI 53532

**DRIVE ASSEMBLY  
ENCORE DHR**

|                |                |      |
|----------------|----------------|------|
| SCALE: 1/4 = 1 | DWG. NO.       | REV. |
| DATE: 11-11-03 | AGL-64-C4686-4 | B    |

# Bill Of Material

**Part #:** AGL-64-K4687-4

**Appl #:**

**Assy #:** AGLC4686-4

**BOM Rev:** C

**Model #:**

**Rev:**

**Rev:** B

**Date:** 11/11/2003

**Description:** DRIVE ASSEMBLY, ENCORE DHR

| Item: | Part #:        | Description:   | Qty: |
|-------|----------------|--|------|
| 1     | AGL-XX-B4684   | IDLER TENSIONER, 1.675 LG.                           | 1    |
| 2     | AGL-XX-B4685   | IDLER TENSIONER, 2.69 LG.                            | 1    |
| 6     | AGL-64-B0928-1 | IDLER TENSIONER, 3.63 LG.                            | 1    |
| 20    | 000912-15      | SPROCKET, 3/8 PITCH, 0.50 DIA BORE, 15 TOOTH         | 3    |
| 21    | 001460-15      | SPROCKET, 3/8 PITCH, 1 BORE, 15 TEETH IMPORT         | 1    |
| 22    | 012022-04      | NOW PURCHASED AS PART OF #012022-01                  | 1    |
| 23    | 012254-18      | SPROCKET, 3/8 PITCH, 7/8 BORE, 18 TEETH IMPORT       | 1    |
| 24    | 001401-24      | SPROCKET, 3/8 PITCH, 1-1/4 BORE, 24 TEETH            | 2    |
| 25    | 001401-45      | SPROCKET, 3/8 PITCH, 1-1/4 BORE, 45 TEETH IMPORT     | 1    |
| 26    | 000732-06      | BUSHING, BRONZE, 3/8 ID, 1/2 OD, 3/4 LG              | 3    |
| 27    | 012417-06      | HHCS, 5/16-18UNC, 3/4 LG, BLACK OXIDE                | 6    |
| 28    | 000343-08      | HHCS, 3/8-16UNC, 1 LG, ZINC                          | 4    |
| 29    | 000493-08      | WASHER, LOCK, 3/8 DIA, SPLIT, ZINC                   | 4    |
| 30    | 000207-08      | WASHER, FLAT, SAE, 3/8 DIA, 13/16 OD, 13/32 ID, ZINC | 4    |
| 31    | 000337-12      | HHCS, 1/4-20UNC, 1-1/2 LG, ZINC                      | 4    |
| 32    | 001350-06      | WASHER, FLAT, USS, 1/4 DIA, 3/4 OD, 5/16 ID, ZINC    | 8    |
| 33    | 012495-03      | WASHER, RUBBER, 2.25 OD. X .38 ID. X .13 THICK       | 4    |
| 34    | 000651-05      | NUT, HEX, NYLOCK, 1/4-20UNC, ZINC                    | 4    |
| 35    | 012022-01      | GEAR BOX, 60:1,56C, WITH SINGLE OUTPUT SHAFT         | 1    |
| 36    | 012141-97      | CHAIN, #35, 97 PITCHES                               | 1    |
| 37    | 001275         | CHAIN, #35, CONNECTING LINK                          | 3    |
| 38    | 002696-01      | MOTOR, PERM MAGNET, 180VDC, 1/2 HP, 1750 RPM         | 1    |
| 39    | 000635-08      | SHOULDER SCREW, 3/8 DIA, 1 LG (5/16-18UNC)           | 3    |
| 40    | 001330-16      | KEY, 0.25 SQ. 2.00 LG, CRS                           | 1    |
| 41    | 001330-08      | KEY, 0.25 SQ, 1.00 LG, CRS                           | 1    |
| 42    | 001317-16      | KEY, 0.188 SQ, 2.00 LG, CRS                          | 1    |
| 43    | 012141-168     | CHAIN, #35, 168 PITCHES                              | 1    |
| 44    | 012415-08      | WASHER, LOCK, 8mm DIA, SPLIT, BLACK OXIDE            | 6    |

**Part #:** AGL-64-K4687-4

**Appl #:**

**Assy #:** AGLC4686-4

**BOM Rev:** C

**Model #:**

**Rev:**

**Rev:** B

**Date:** 11/11/2003

**Description:** DRIVE ASSEMBLY, ENCORE DHR

---

| <b>Item:</b> | <b>Part #:</b> | <b>Description:</b>  | <b>Qty:</b> |
|--------------|----------------|--|-------------|
| 45           | 012141-117     | CHAIN, #35, 117 PITCHES                                      | 1           |
| 46           | 012416-07      | WASHER, FLAT, SAE, 5/16 DIA, 11/16 OD, 11/32 ID, BLACK OXIDE | 6           |

---

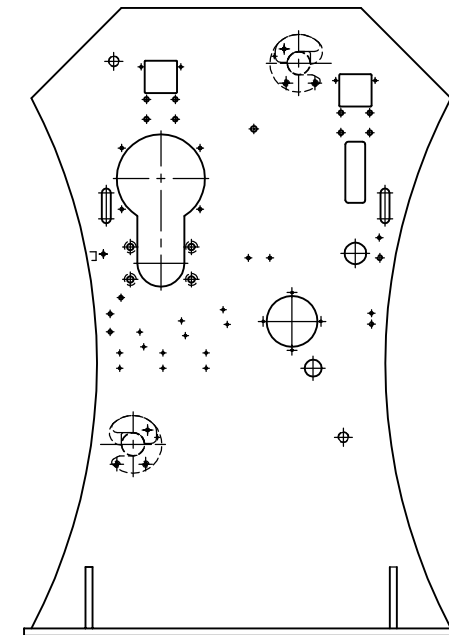
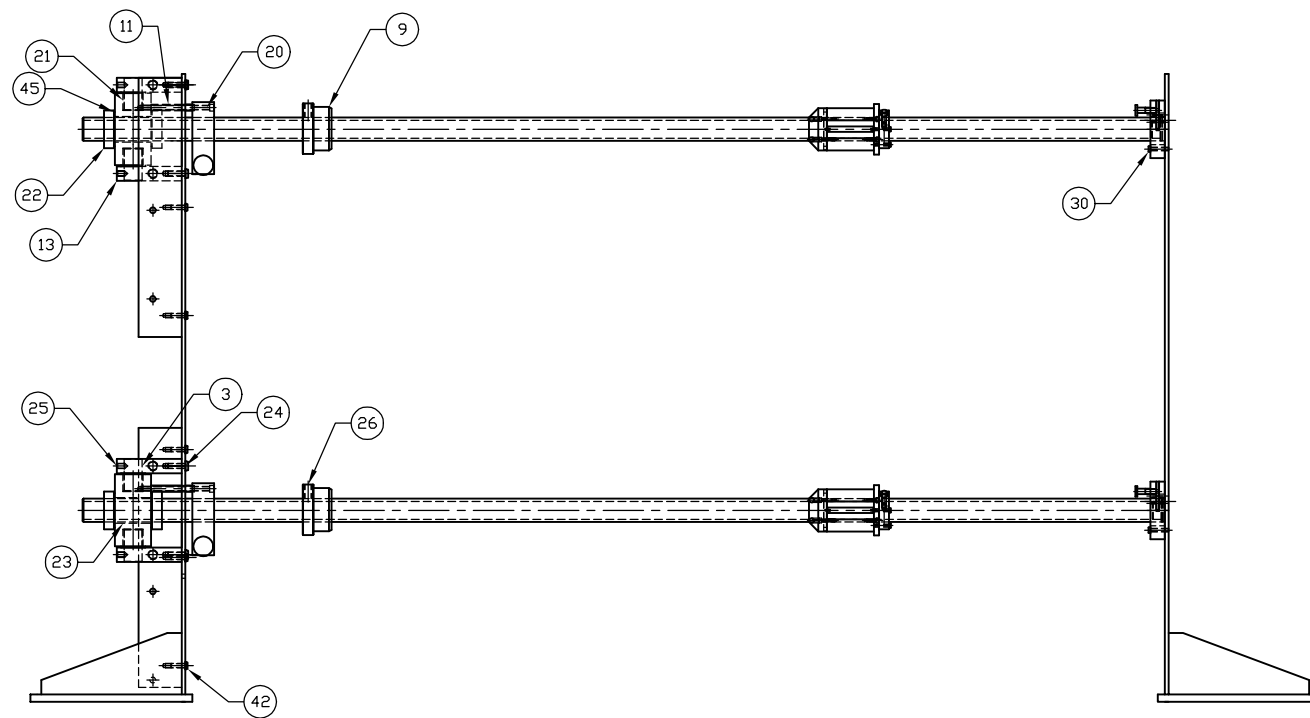
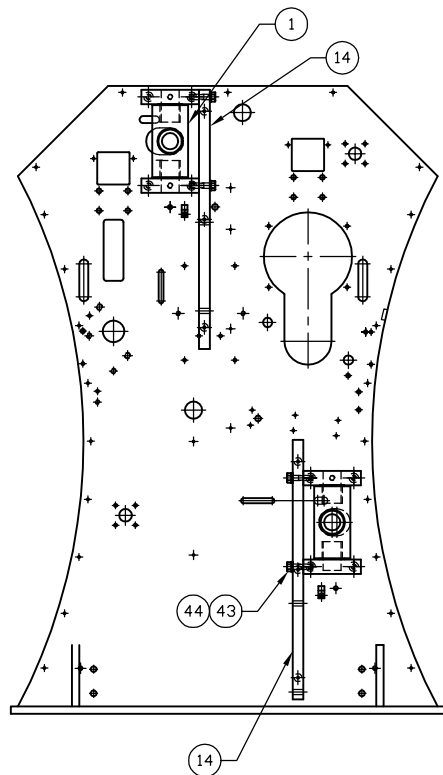
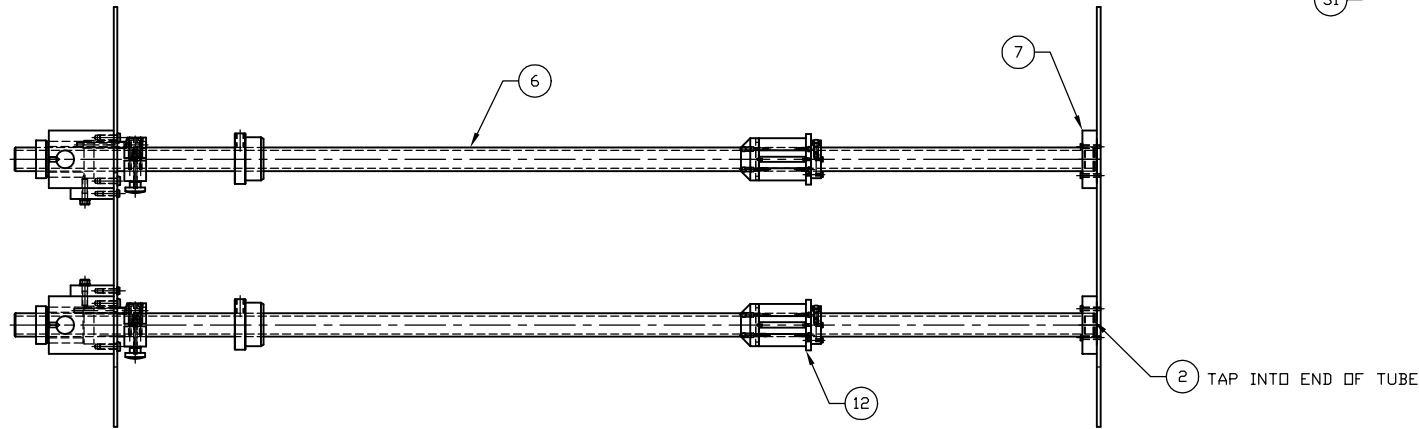
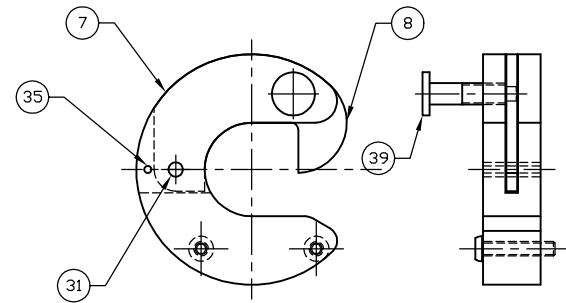
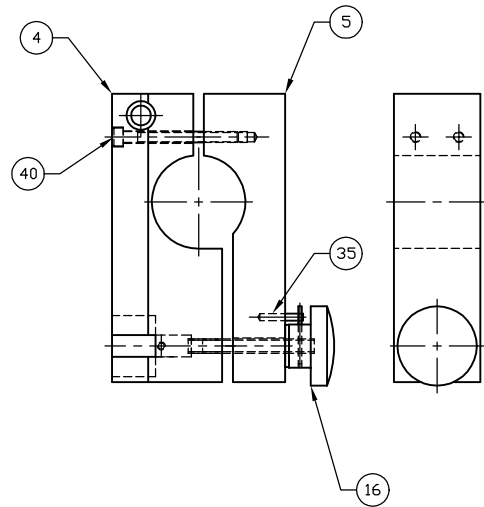

|             |   |                                       |          |      |      |
|-------------|---|---------------------------------------|----------|------|------|
| REV. NO.    | A | #43 WAS 5/16-18UNC, #44 WAS 5/16 DIA. | 11-11-03 | GFT  | 2105 |
| DESCRIPTION |   |                                       | DATE     | INT. | ECN  |

|                              |                   |                          |          |   |         |
|------------------------------|-------------------|--------------------------|----------|---|---------|
| <b>BREAK ALL SHARP EDGES</b> |                   | <b>DO NOT SCALE DWG.</b> |          |  Advanced Greig Laminators, Inc.<br>801 Burton Blvd.<br>DeForest, WI 53532 |         |
| UNLESS OTHERWISE SPECIFIED   | MAT'L: AGLK4760-2 | FINISH:                  |          | UNWIND ASSEMBLY<br>NO DISPLAY, ENCORE SERIES  |         |
| 0.00 +/-0.015                |                   | JOB NO.                  | QTY.     | DWG. BY: GFT  | CHK BY: |
| 0.000 +/-0.005               |                   | SCALE: 1/6 = 1           | DWG. NO. | DATE: 4-24-03   | REV. A  |
| ANGLES +/-5°                 |                   | AGL-64-D4759-2           |          |   |         |

# Bill Of Material

**Part #:** AGL-64-K4760-2

**Appl #:**

**Assy #:** AGLD4759-2

**BOM Rev:** B

**Model #:**

**Rev:**

**Rev:** A

**Date:** 4/24/2003

**Description:** UNWIND ASSEMBLY, NO DISPLAY, ENCORE

| Item: | Part #:        | Description:  | Qty: |
|-------|----------------|---|------|
| 1     | AGL-XX-B4750   | PIVOT BLOCK   | 2    |
| 2     | AGL-XX-B5036   | PLUG, TUBE  | 2    |
| 3     | AGL-XX-B4752   | PIVOT SHAFT   | 4    |
| 4     | AGL-XX-C4753-1 | BRAKE, BOTTOM   | 2    |
| 5     | AGL-XX-C4754-1 | BRAKE, TOP  | 2    |
| 6     | AGL-64-B4863   | UNWIND TUBE, ENCORE   | 2    |
| 7     | AGL-XX-B4323-1 | UNWIND SHAFT SUPPORT  | 2    |
| 8     | AGL-XX-B4324-1 | UNWIND SHAFT LATCH  | 2    |
| 9     | AGL-64-B0044   | CORE COLLAR   | 2    |
| 11    | AGL-XX-B4756   | BRAKE SPACER  | 2    |
| 12    | AGL-XX-B2917-1 | CORE HOLDER, 1-5/8 BORE (ENCORE)                            | 2    |
| 13    | AGL-64-B0004   | SHAFT BRACE, CANTILEVERED UNWIND                            | 4    |
| 14    | AGL-XX-B4857   | SUPPORT RIB   | 2    |
| 16    | AGL-XX-B4668-2 | KNOB ASSEMBLY, ENCORE                                       | 2    |
| 20    | 000011-26      | SHCS, 5/16-18UNC, 4-1/2 LG, BLACK                           | 2    |
| 21    | 012409-20      | BEARING, FLANGED, 1.25 ID x 1.41 OD. x 1.25 LG. PAPZ2020P10 | 4    |
| 22    | 000417-26      | COLLAR, SHAFT, 2-PIECE, 1.63 DIA .69 WIDE                   | 4    |
| 23    | 012410-16      | BEARING, 1.63 ID. x 1.78 OD. x 1.00 LG.                     | 4    |
| 24    | 000063-10      | BHSCS, 3/8-16UNC, 1-1/4 LG, BLACK                           | 8    |
| 25    | 000135-08      | SSS, CUP PT, 3/8-16UNC, 1/2 LG, BLACK                       | 4    |
| 26    | 012265-06      | SSS, NYLON TIPPED, 1/2-13UNC, 3/4 LG. BLACK                 | 2    |
| 30    | 000059-10      | BHSCS, 1/4-20UNC, 1-1/4 LG, BLACK                           | 4    |
| 31    | 000285-08      | PIN, DOWEL, 1/4 DIA, 1 LG                                   | 2    |
| 32    | 000207-06      | WASHER, FLAT, SAE, 1/4 DIA, 5/8 OD, 9/32 ID, ZINC           | 2    |
| 35    | 000217-06      | PIN, SPRING, 1/8 DIA, 3/4 LG                                | 2    |
| 39    | 012143-07      | PLUNGER, DELRIN KNOB, LOCKING, 1/4-20UNC                    | 2    |
| 40    | 000035-16      | SHCS, #10-32UNF, 2 LG, BLACK                                | 4    |
| 42    | 000061-08      | BHSCS, 5/16-18UNC, 1 LG, BLACK                              | 6    |



**Part #:** AGL-64-K4760-2

**Appl #:**

**Assy #:** AGLD4759-2

**BOM Rev:** B

**Model #:**

**Rev:**

**Rev:** A

**Date:** 4/24/2003

**Description:** UNWIND ASSEMBLY, NO DISPLAY, ENCORE

---

| <b>Item:</b> | <b>Part #:</b> | <b>Description:</b>                                    | <b>Qty:</b> |
|--------------|----------------|--|-------------|
| 43           | 000343-12      | HHCS, 3/8-16UNC, 1-1/2 LG, ZINC                        | 4           |
| 44           | 000493-08      | WASHER, LOCK, 3/8 DIA, SPLIT, ZINC                     | 4           |
| 45           | 012429-26      | SHIM WASHER, 1-5/8 ID. X 2-3/8 OD. X .075 THICK, STEEL | 4           |

---

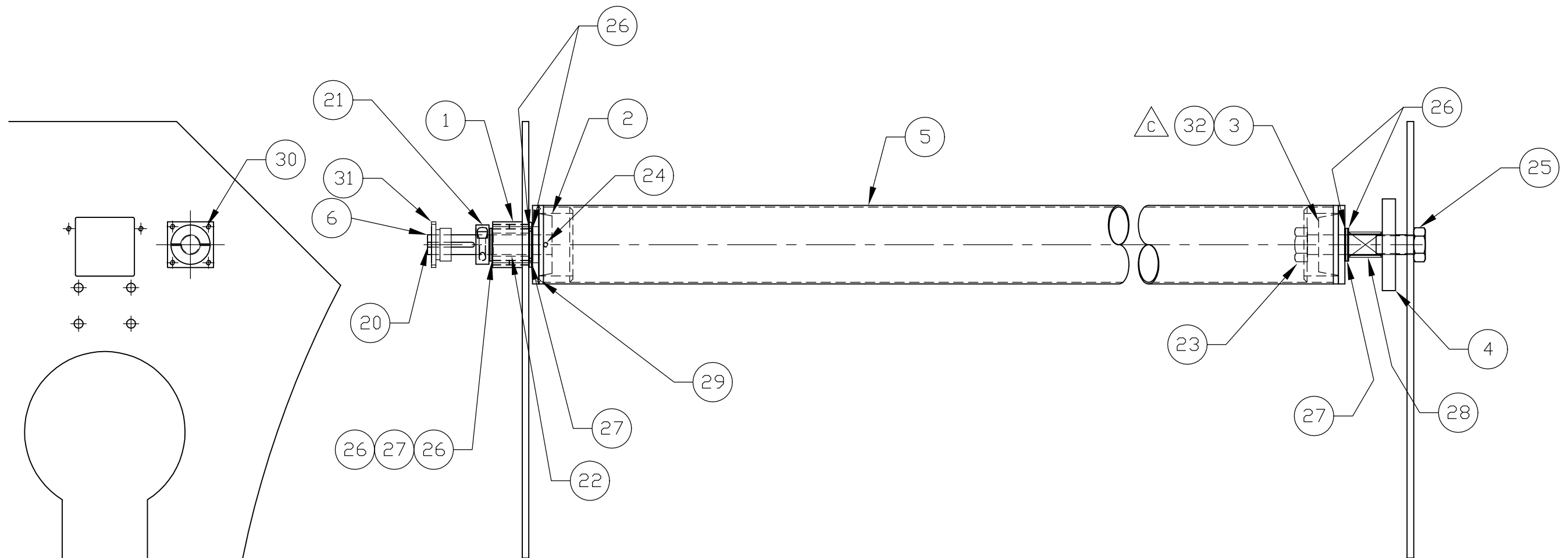

ASSEMBLY NOTES:

1. #1 HAS PRICK PUNCH INDICATING DATUM SURFACE. THIS SURFACE SHOULD BE MOUNTED TO SIDEPLATE. BUSHING SHOULD EXTEND OUT 1/8" ON DATUM SURFACE SIDE
2. REAM BUSHING (#22) TO .752 B

*BREAK ALL SHARP EDGES*  
 DO NOT SCALE DWG.



Advanced Greig Laminators, Inc.  
 801 Burton Blvd.  
 DeForest, WI 53532

LINER WINDUP  
 ASSEMBLY, ENCORE

|         |                                 |          |      |      |
|---------|---------------------------------|----------|------|------|
| C       | ADDED #32                       | 1-25-06  | GFT  | 2135 |
| B       | ADDED NOTE #2                   | 11-29-04 | GFT  |      |
| A       | REVISED TO SHOW BOM CORRECTIONS | 10-27-03 | GFT  |      |
| REV NO. | DESCRIPTION                     | DATE     | INT. | ECN  |

|                                 |  |                      |         |
|---------------------------------|--|----------------------|---------|
| UNLESS OTHERWISE SPECIFIED      |  | MAT'L:<br>AGLK4731-1 |         |
| 0.00 +/-0.015<br>0.000 +/-0.005 |  | FINISH:              |         |
| ANGLES +/- .5°                  |  | JOB NO.              | QTY.    |
|                                 |  | DWG. BY:<br>GFT      | CHK BY: |

|                |                            |           |
|----------------|----------------------------|-----------|
| SCALE: 1/4 = 1 | DWG. NO.<br>AGL-64-B4730-1 | REV.<br>C |
| DATE: 4-2-03   |                            |           |

# Bill Of Material

**Part #:** AGL-64-K4731-1

**Appl #:**

**Assy #:** AGLB4730-1

**BOM Rev:** D

**Model #:**

**Rev:**

**Rev:** C

**Date:** 3/12/2003

**Description:** LINER WINDUP ASSEMBLY, ENCORE

| Item: | Part #:      | Description:                                      | Qty: |
|-------|--------------|---|------|
| 1     | AGL-XX-B4723 | BEARING BLOCK, WINDUP                             | 1    |
| 2     | AGL-XX-B4724 | DRIVE HUB, WINDUP                                 | 1    |
| 3     | AGL-XX-B4725 | IDLER HUB, WINDUP                                 | 1    |
| 4     | AGL-XX-B4726 | ADJUSTMENT KNOB, WINDUP                           | 1    |
| 5     | AGL-64-B4931 | WINDUP TUBE SUB ASSEMBLY                          | 1    |
| 6     | AGL-XX-B5222 | SHAFT, WINDUP                                     | 1    |
| 20    | 001317-08    | KEY, 0.188 SQ, 1.00 LG, CRS                       | 1    |
| 21    | 000411-12    | COLLAR, SHAFT, 0.75 DIA BORE, 1/2 WIDE            | 1    |
| 22    | 000721-10    | BUSHING, BRONZE, 3/4 ID. 7/8 OD. 1-1/4 LG         | 1    |
| 23    | 000395-24    | HHCS, 3/4-16UNF, 4 LG, ZINC                       | 1    |
| 24    | 000129-08    | SSS, CUP PT, #10-24UNC, 1/2 LG, BLACK             | 1    |
| 25    | 000198-12    | NUT, HEX, JAM, 3/4-16UNF, ZINC                    | 1    |
| 26    | 000777-12    | BEARING, THRUST, WASHER, 3/4 DIA BORE, .03 THICK  | 6    |
| 27    | 000776-12    | BEARING, THRUST, NEEDLE, 3/4 BORE                 | 3    |
| 28    | 012402-5     | SPRING, COMPRESSION, 0.97 OD, .072 THICK, 1.75 LG | 1    |
| 29    | 000922-21    | O-RING, BUNA, 1/8 THICK, 2-5/8 ID, 2-7/8 OD       | 1    |
| 30    | 000057-06    | BHSCS, #10-24UNC, 3/4 LG, BLACK                   | 4    |
| 31    | 012161-13    | SPROCKET, 3/8 PITCH, 0.75 DIA BORE, 13 TOOTH      | 1    |
| 32    | 000722-06    | BUSHING, BRONZE, 3/4 ID, 1 OD, 3/4 LG             | 1    |

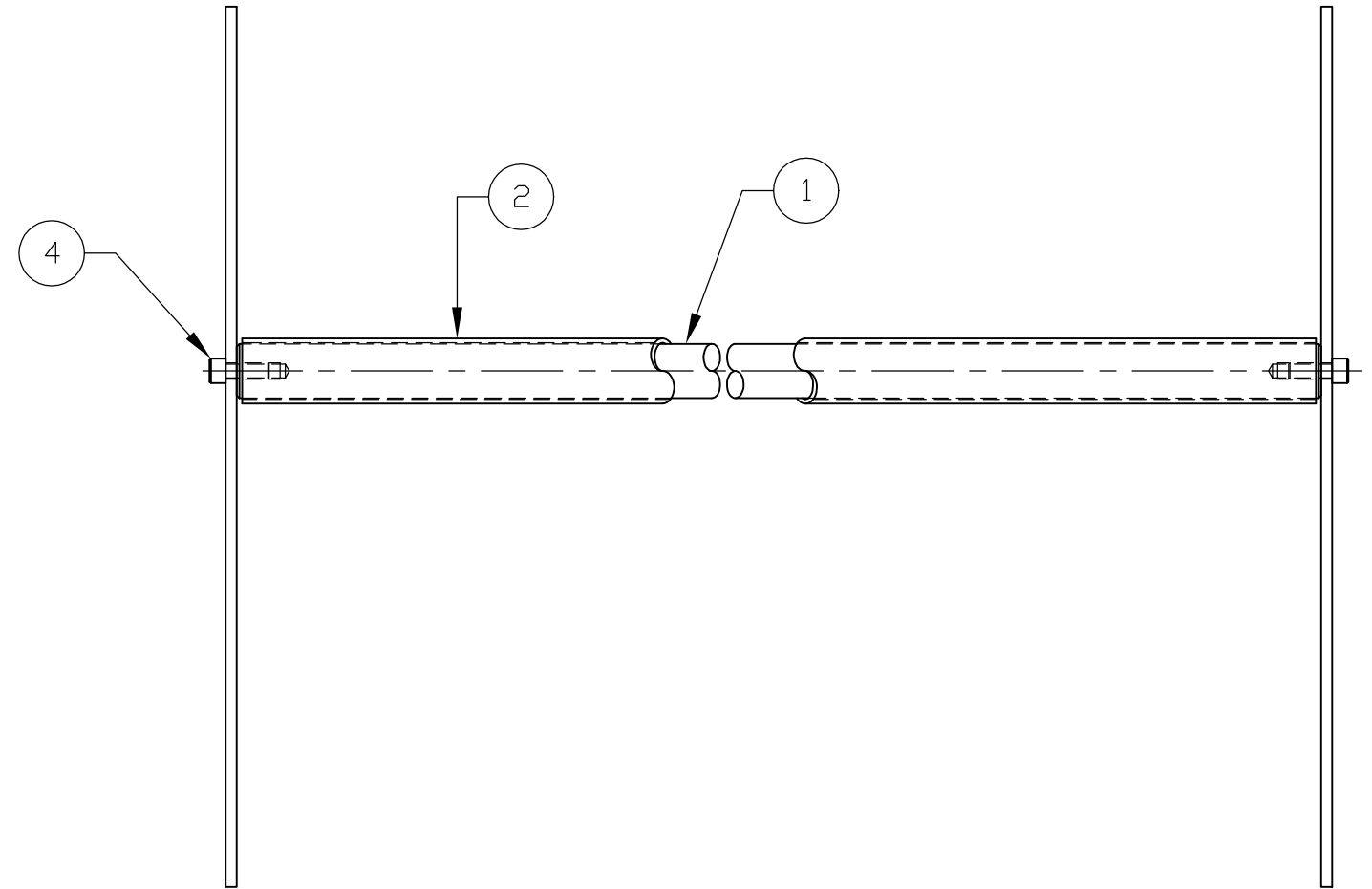
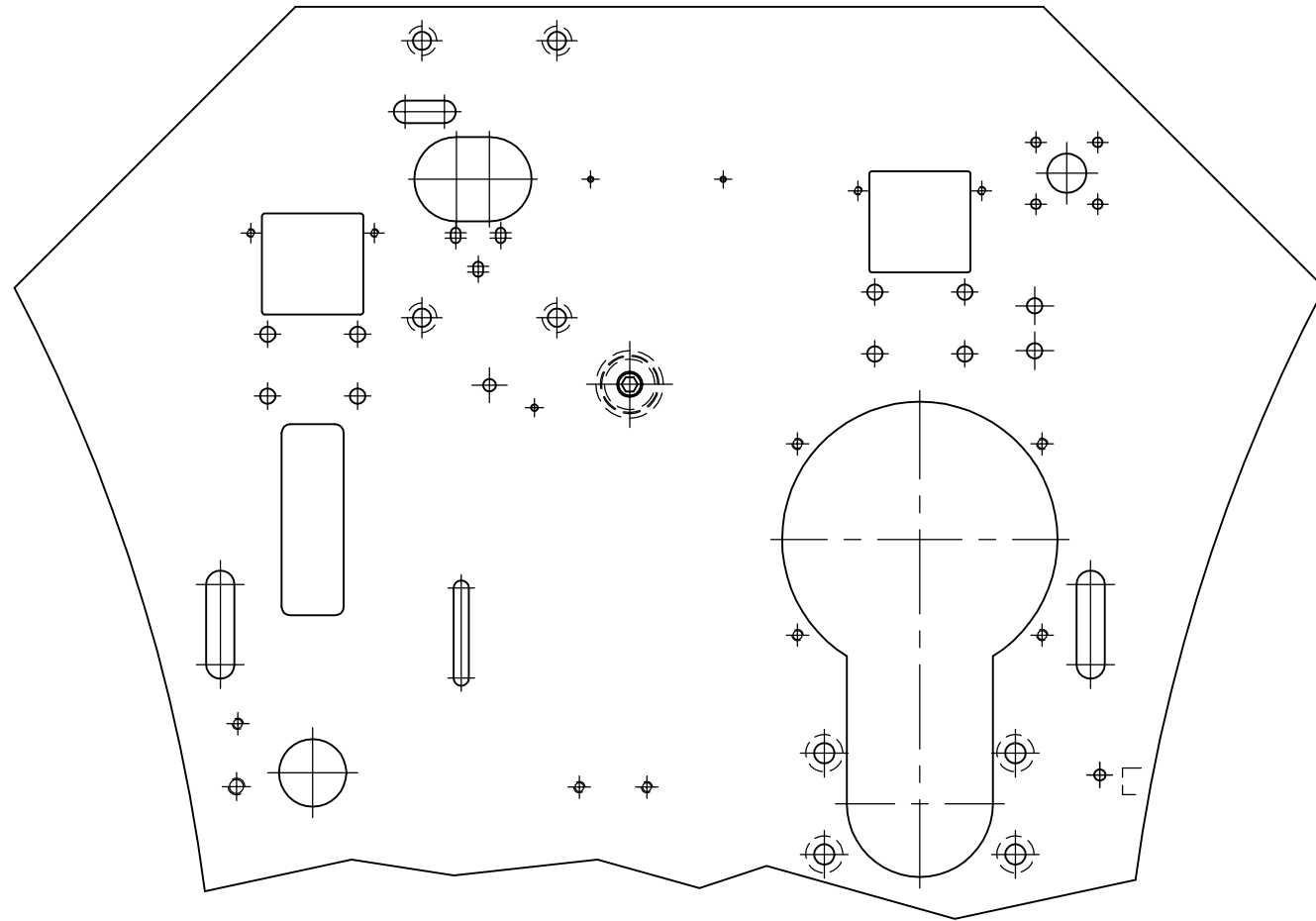

BREAK ALL SHARP EDGES

DO NOT SCALE DWG.

UNLESS OTHERWISE SPECIFIED

0.00 +/-0.015  
0.000 +/-0.005

ANGLES +/- .5°

MAT'L:  
AGLK4748

FINISH:

|         |      |          |        |
|---------|------|----------|--------|
| JOB NO. | QTY. | DWG. BY. | CHK BY |
|         |      | GFT      |        |



Advanced Greig Laminators, Inc.  
801 Burton Blvd.  
DeForest, WI 53532

IDLER ASSEMBLY

SCALE: 1/4 = 1

DATE: 11-6-02

DWG. NO.

AGL-64-B4749

REV.

| REV NO. | DESCRIPTION | DATE | INT. | ECN |
|---------|-------------|------|------|-----|
|         |             |      |      |     |

---

# Bill Of Material

---

**Part #:** AGL-64-K4748

**Appl #:**

**Assy #:** AGLB4749

**BOM Rev:** -

**Model #:**

**Rev:**

**Rev:** -

**Date:** 10/31/2002

**Description:** IDLER ASSEMBLY

---

| Item: | Part #:      | Description:                   | Qty: |
|-------|--------------|--------------------------------|------|
| 1     | AGL-64-B4286 | IDLER SHAFT                    | 1    |
| 2     | AGL-64-B4287 | IDLER SLEEVE                   | 1    |
| 4     | 000013-06    | SHCS, 3/8-16UNC, 3/4 LG, BLACK | 2    |

---

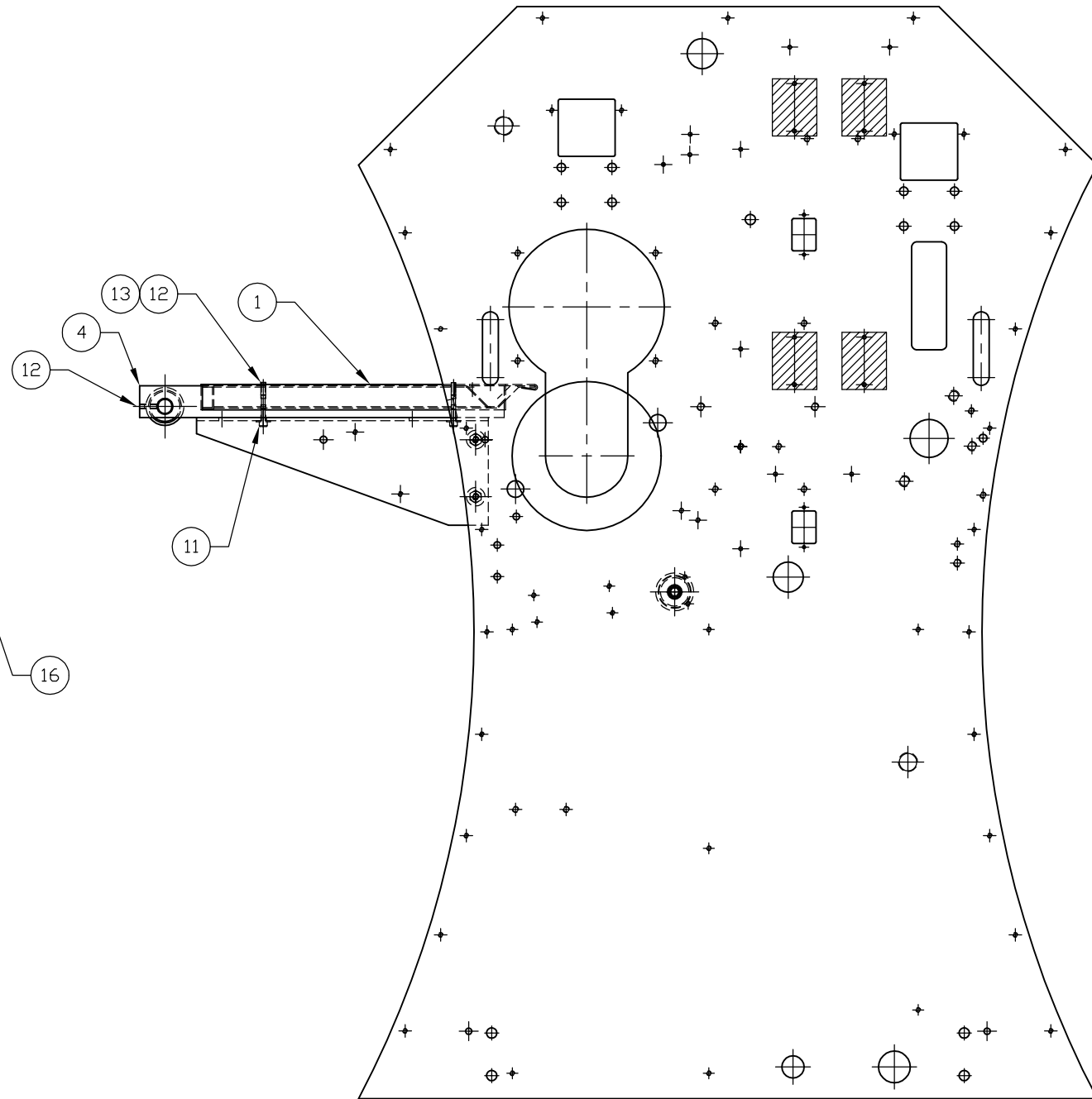
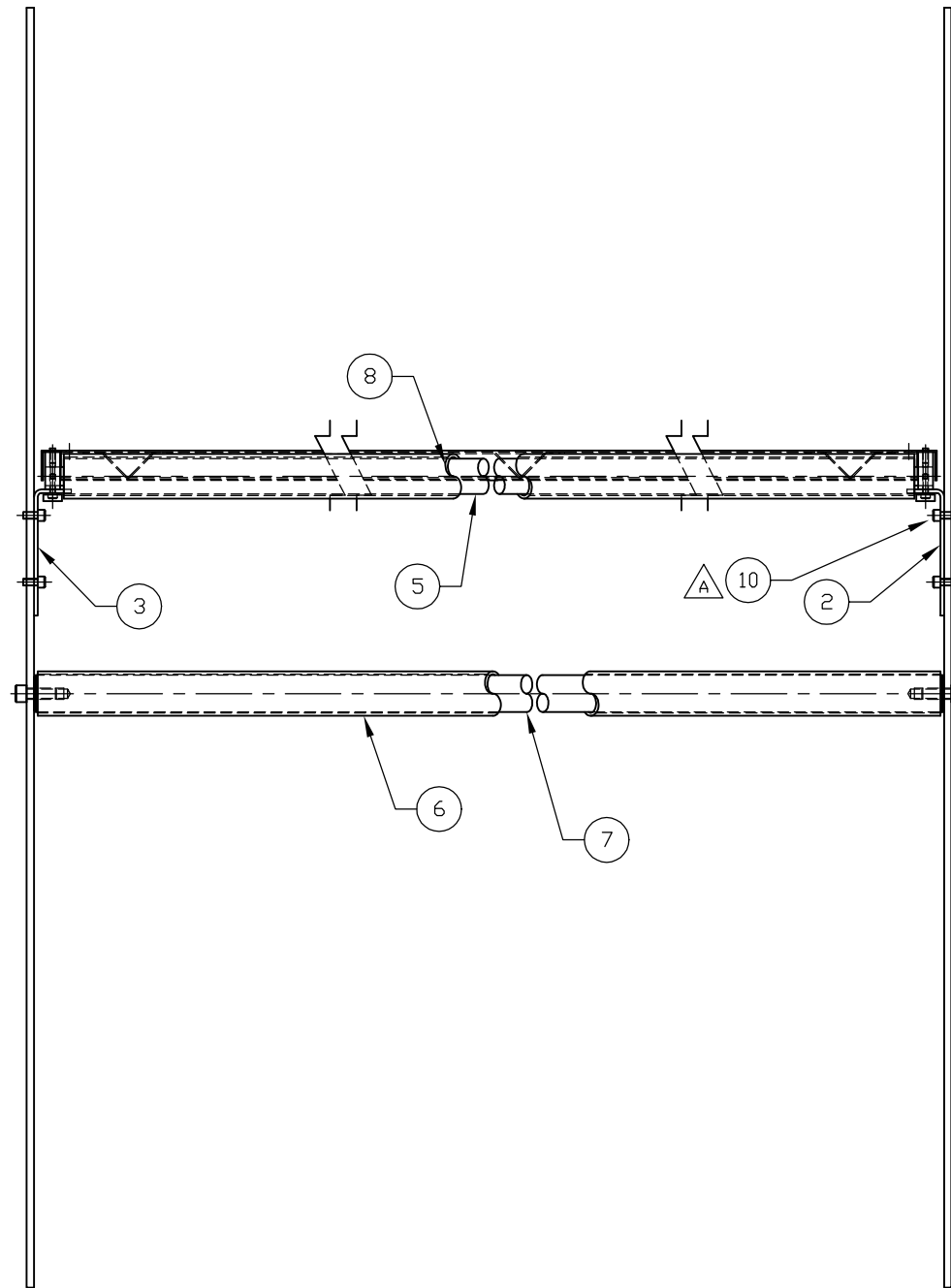

| A        | REMOVED #14 | 3-29-04 | GFT  |     |
|----------|-------------|---------|------|-----|
| REV. NO. | DESCRIPTION | DATE    | INT. | ECN |

**BREAK ALL SHARP EDGES**  
**DO NOT SCALE DWG.**

UNLESS OTHERWISE SPECIFIED  
 0.00 +/-0.015  
 0.000 +/-0.005  
 ANGLES +/-0.5°

|   |                                 |
|---|---------------------------------|
|  Advanced Greig Laminators, Inc.<br>801 Burton Blvd.<br>DeForest, WI 53532 |                                 |
| <b>INFEEED TABLE, REMOVABLE ENCORE SERIES</b>   |                                 |
| SCALE: 1/4" = 1"<br>DATE: 4-9-03  | DWG. NO.<br><b>AGL-64-C4973</b> |
| JOB NO. QTY. DWG. BY. CHK BY.<br>GFT  | REV.<br><b>A</b>                |

---

# Bill Of Material

---

**Part #:** AGL-64-K4972

**Appl #:**

**Assy #:** AGLC4973

**BOM Rev:** A

**Model #:**

**Rev:**

**Rev:** -

**Date:** 4/9/2003

**Description:** INFEEED TABLE, REMOVABLE, ENCORE SERIES

---

| Item: | Part #:         | Description:                                      | Qty: |
|-------|-----------------|---|------|
| 1     | AGL-64-C0955-02 | INFEEED TABLE, REMOVABLE (WHITE)                  | 1    |
| 2     | AGL-64-B0082-02 | TABLE SUPPORT, RIGHT HAND (WHITE)                 | 1    |
| 3     | AGL-64-B0083-02 | TABLE SUPPORT, LEFT HAND (WHITE)                  | 1    |
| 4     | AGL-64-B1129    | ROLLER SUPPORT, AGL 64                            | 2    |
| 5     | AGL-64-B5039    | TABLE ROLLER SHAFT, REMOVABLE TABLE               | 1    |
| 6     | AGL-64-B4287    | IDLER SLEEVE                                      | 1    |
| 7     | AGL-64-B4286    | IDLER SHAFT                                       | 1    |
| 8     | AGL-64-B4287-2  | IDLER SLEEVE, REMOVABLE TABLE                     | 1    |
| 10    | 000009-04       | SHCS, 1/4-20UNC, 1/2 LG, BLACK                    | 4    |
| 11    | 000007-04       | SHCS, #10-24UNC, 1/2 LG, BLACK                    | 4    |
| 12    | 000129-08       | SSS, CUP PT, #10-24UNC, 1/2 LG, BLACK             | 6    |
| 13    | 000207-04       | WASHER, FLAT, SAE, #10 DIA, 1/2 OD, 7/32 ID, ZINC | 4    |
| 16    | 000013-06       | SHCS, 3/8-16UNC, 3/4 LG, BLACK                    | 2    |

---

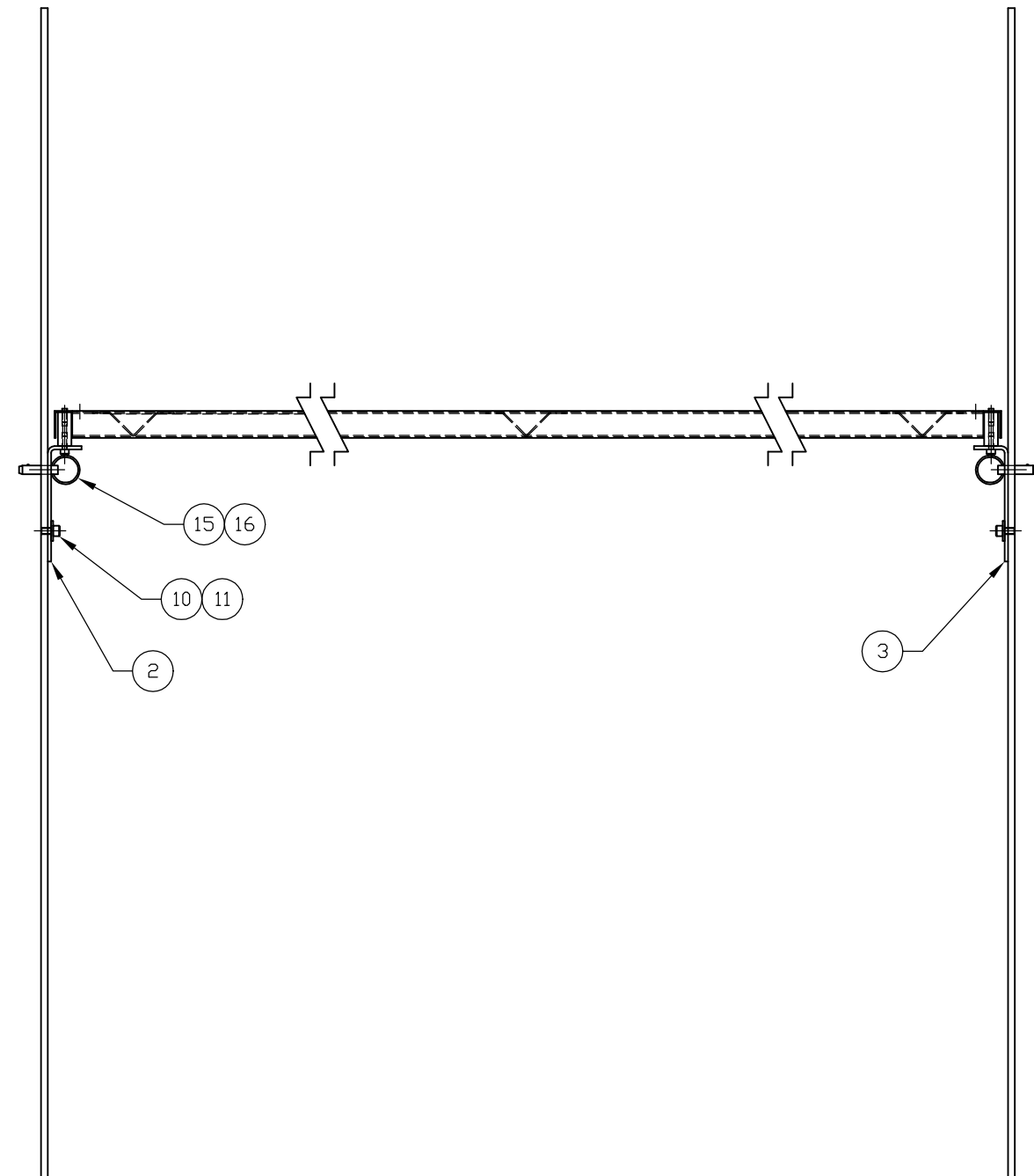
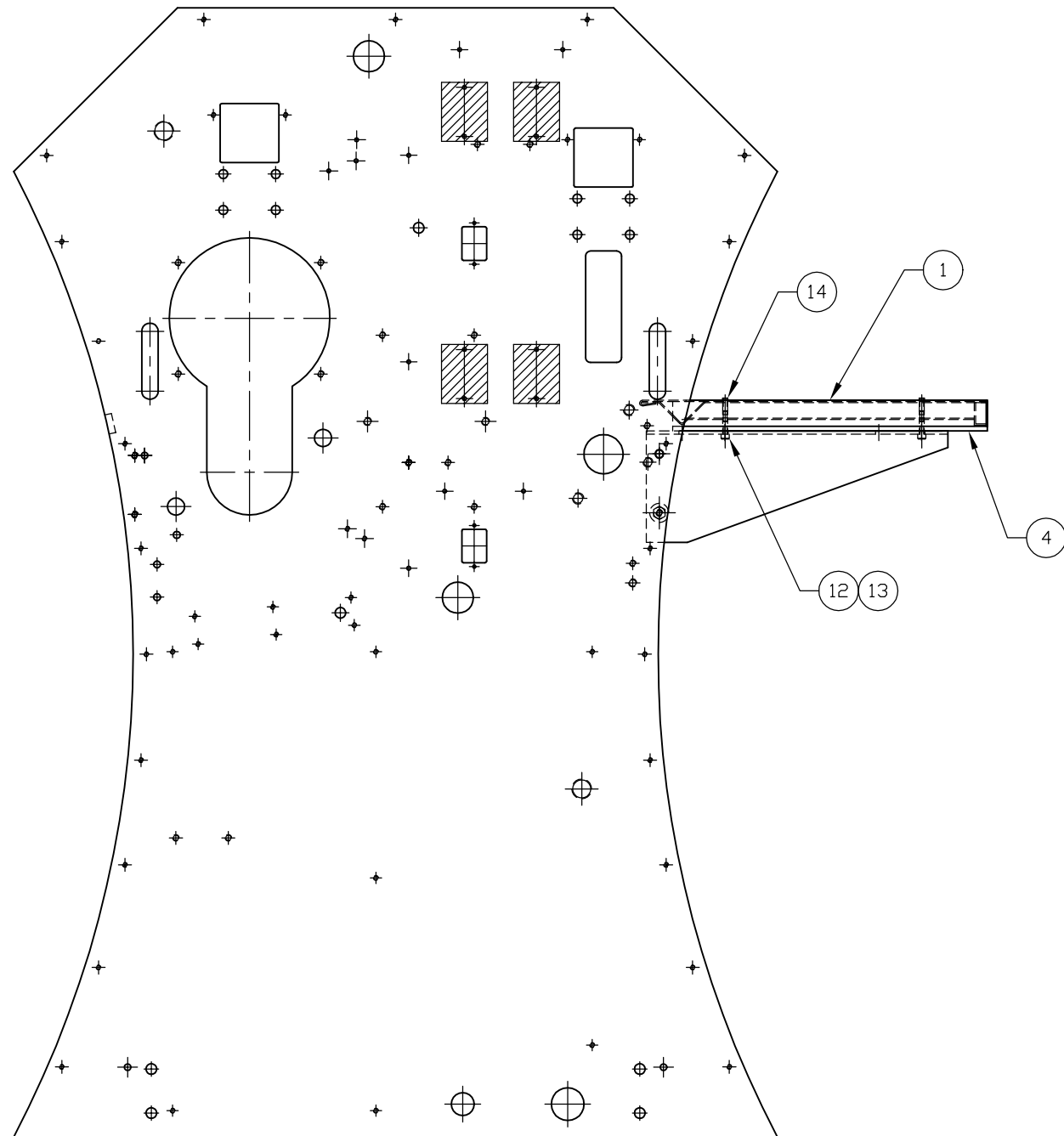

| REV NO. | DESCRIPTION | DATE | INT. | ECN |
|---------|-------------|------|------|-----|
|         |             |      |      |     |

|                                 |  |                    |      |  |         |                |                                 |      |
|---------------------------------|--|--------------------|------|--|---------|----------------|---------------------------------|------|
| <b>BREAK ALL SHARP EDGES</b>    |  |                    |      |  <b>Advanced Greig Laminators, Inc.</b><br>801 Burton Blvd.<br>DeForest, WI 53532 |         |                |                                 |      |
| <b>DO NOT SCALE DWG.</b>        |  |                    |      |  |         |                |                                 |      |
| UNLESS OTHERWISE SPECIFIED      |  | MAT'L:<br>AGLK4974 |      | <b>OUTFEED TABLE, REMOVABLE ENCORE SERIES</b>  |         |                |                                 |      |
| 0.00 +/-0.015<br>0.000 +/-0.005 |  | FINISH:            |      |  |         |                |                                 |      |
| ANGLES +/- .5°                  |  | JOB NO.            | QTY. | DWG. BY.<br>GFT  | CHK BY. | SCALE: 1/4 = 1 | DWG. NO.<br><b>AGL-64-C4975</b> | REV. |
|                                 |  |                    |      |  |         | DATE: 4-9-03   |                                 |      |



---

# Bill Of Material

---

**Part #:** AGL-64-K4974

**Appl #:**

**Assy #:** AGLC4975

**BOM Rev:** -

**Model #:**

**Rev:**

**Rev:** -

**Date:** 4/9/2003

**Description:** OUTFEED TABLE, REMOVABLE, ENCORE SERIES

---

| Item: | Part #:         | Description:                                      | Qty: |
|-------|-----------------|---|------|
| 1     | AGL-64-C0955-02 | INFEEED TABLE, REMOVABLE (WHITE)                  | 1    |
| 2     | AGL-64-B0083-02 | TABLE SUPPORT, LEFT HAND (WHITE)                  | 1    |
| 3     | AGL-64-B0082-02 | TABLE SUPPORT, RIGHT HAND (WHITE)                 | 1    |
| 4     | AGL-64-B0923    | MOUNTING ENDS, OUTFEED TABLE                      | 2    |
| 10    | 000009-04       | SHCS, 1/4-20UNC, 1/2 LG, BLACK                    | 2    |
| 11    | 000207-06       | WASHER, FLAT, SAE, 1/4 DIA, 5/8 OD, 9/32 ID, ZINC | 2    |
| 12    | 000007-04       | SHCS, #10-24UNC, 1/2 LG, BLACK                    | 4    |
| 13    | 000207-04       | WASHER, FLAT, SAE, #10 DIA, 1/2 OD, 7/32 ID, ZINC | 4    |
| 14    | 000129-08       | SSS, CUP PT, #10-24UNC, 1/2 LG, BLACK             | 4    |
| 15    | 012362-01       | PIN, QUICK RELEASE, 5/16 DIA, 0.8 LG              | 2    |
| 16    | 012029-03       | LANYARD, QUICK RELEASE PIN, 6" LG., MTG. TAB      | 2    |

---

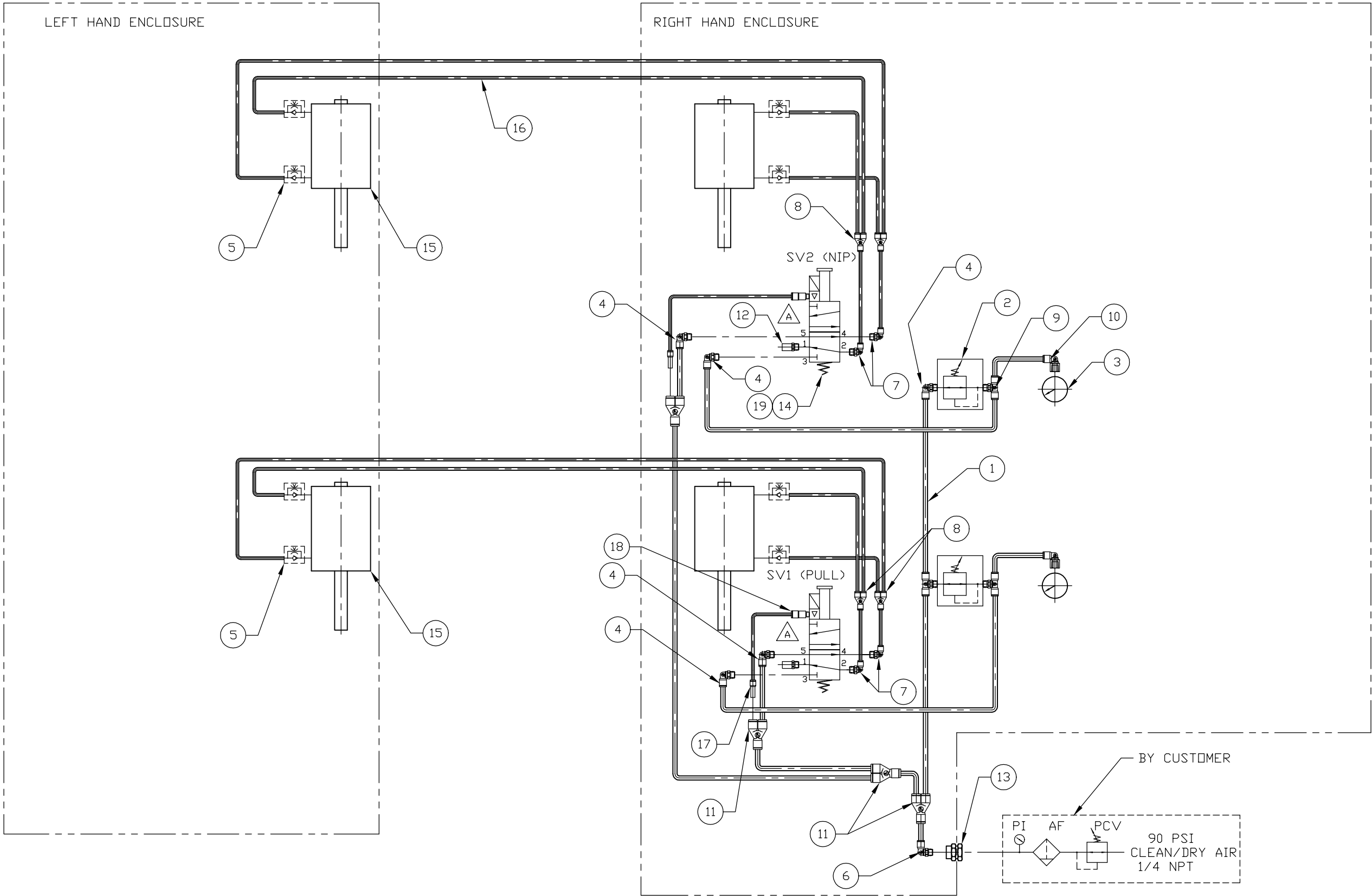

**BREAK ALL SHARP EDGES**  
**DO NOT SCALE DWG.**

**AGL** Advanced Greig Laminators, Inc.  
 801 Burton Blvd.  
 DeForest, WI 53532

UNLESS OTHERWISE SPECIFIED  
 0.00 +/-0.015  
 0.000 +/-0.005  
 ANGLES +/-5°

MAT'L:  
 AGLK4721-1

FINISH:  
 JOB NO. QTY. DWG. BY. CHK BY  
 GFT

**PNEUMATIC ASSEMBLY**  
**ENCORE MAXIM & DHR**

SCALE: 1/4 = 1  
 DATE: 4-7-03

DWG. NO.  
**AGL-64-C4720-1**

REV.  
**A**

| REV NO. | DESCRIPTION               | DATE    | INT. | ECN |
|---------|---------------------------|---------|------|-----|
| A       | REVISED TO NUMATICS VALVE | 1-17-07 | GFT  |     |

# Bill Of Material

**Part #:** AGL-64-K4721-1

**Appl #:**

**Assy #:** AGLC4720-1

**BOM Rev:** B

**Model #:**

**Rev:**

**Rev:** A

**Date:** 4/7/2003

**Description:** PNEUMATIC ASSEMBLY, ENCORE MAXIM & DHR

| Item: | Part #:   | Description:   | Qty: |
|-------|-----------|--|------|
| 1     | 012263-05 | TUBING, 1/4" OD, BLACK                                     | 15   |
| 2     | 001294    | REGULATOR, PRESSURE, 1/8NPT                                | 2    |
| 3     | 012234-01 | GUAGE, PRESSURE, 0-100PSI, 1/8NPT, PANEL MNT, CHROME BEZEL | 2    |
| 4     | 000847-10 | FITTING, PIPE, ELBOW, MALE, 1/4 OD, 1/8 NPT                | 5    |
| 5     | 000861-02 | FITTING, PIPE, FLOW CONTROL, ELBOW, 5/32 OD, 1/8 NPT       | 8    |
| 6     | 000847-12 | FITTING, PIPE, ELBOW, MALE, 1/4 OD, 1/4 NPT                | 1    |
| 7     | 000847-06 | FITTING, PIPE, ELBOW, MALE, 5/32 OD, 1/8 NPT               | 4    |
| 8     | 000855-01 | FITTING, TUBE, "Y", 5/32 OD TUBE                           | 4    |
| 9     | 000849-08 | FITTING, PIPE, TEE, BRANCH, 1/4 OD, 1/8 NPT                | 3    |
| 10    | 000851-04 | FITTING, PIPE, ELBOW, FEMALE, 1/4 OD, 1/8 NPT              | 2    |
| 11    | 000855-04 | FITTING, TUBE, "Y", 1/4 OD TUBE                            | 4    |
| 12    | 012011-01 | MUFFLER, EXHAUST, 1/8NPT                                   | 2    |
| 13    | 000822-02 | FITTING, PIPE, BULKHEAD, 1/4 NPT, 3/4-16UNC                | 1    |
| 14    | 012303-04 | VALVE, SOLENOID, 2 POSITION, 24VDC, EXT. PILOT             | 2    |
| 15    | 001457-09 | AIR CYLINDER, 2 DIA BORE, 1 1/4" STROKE, FINE THD          | 4    |
| 16    | 012262-05 | TUBING, 5/32" OD, BLACK                                    | 85   |
| 17    | 012280-05 | FITTING, REDUCER, PLUG-IN, 1/4 TUBE-5/32 TUBE              | 2    |
| 18    | 000845-02 | FITTING, PIPE, MALE, 5/32 OD,10-32UNF                      | 2    |
| 19    | 012572-04 | CONNECTOR, SOLENOID VALVE                                  | 2    |



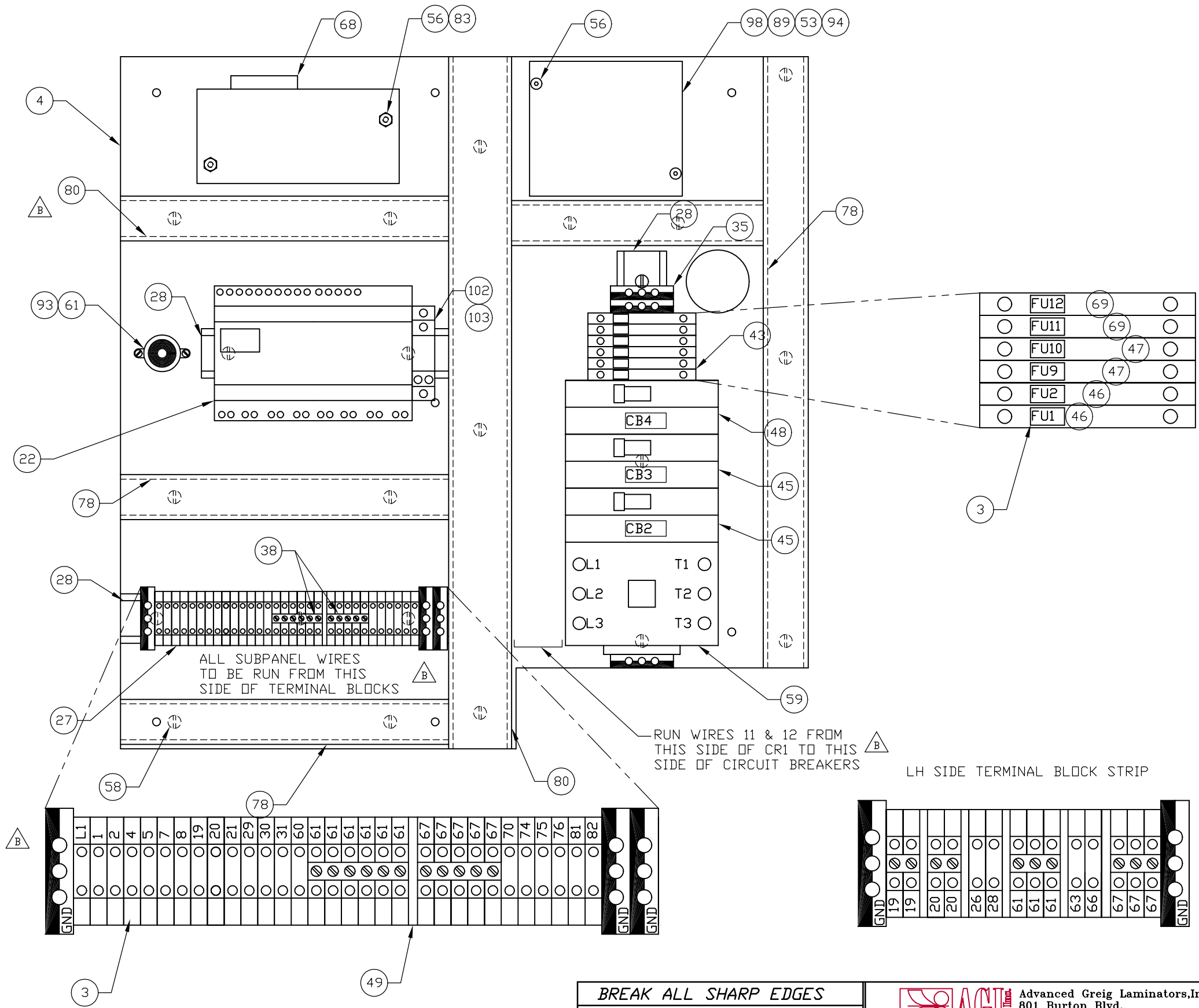

ALL SUBPANEL WIRES  
TO BE RUN FROM THIS  
SIDE OF TERMINAL BLOCKS

RUN WIRES 11 & 12 FROM  
THIS SIDE OF CR1 TO THIS  
SIDE OF CIRCUIT BREAKERS

LH SIDE TERMINAL BLOCK STRIP

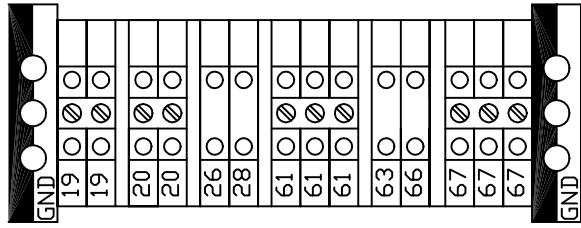
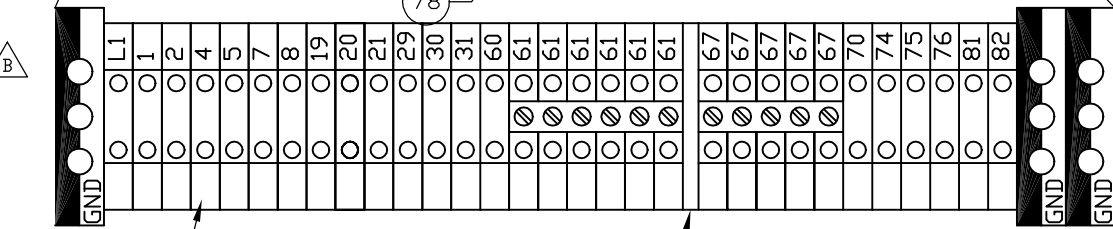

|         |                                      |         |      |     |
|---------|--------------------------------------|---------|------|-----|
| B       | ADDED NOTES, MOVED LABELS, 78 WAS 80 | 2-23-04 | GFT  |     |
| A       | REVISED PANEL LAYOUT                 | 1-9-04  | GFT  |     |
| REV NO. | DESCRIPTION                          | DATE    | INT. | ECN |

**BREAK ALL SHARP EDGES**  
**DO NOT SCALE DWG.**

UNLESS OTHERWISE SPECIFIED  
0.00 +/-0.015  
0.000 +/-0.005  
ANGLES +/-5°

MAT'L:  
FINISH:  
JOB NO. QTY. DWG. BY. CHK BY  
GFT

**AGL** Advanced Greig Laminators, Inc.  
801 Burton Blvd.  
DeForest, WI 53532

**SUBPANEL ASSEMBLY**  
**ENCORE DHR**

SCALE: 1/2" = 1"  
DATE: 7-25-03

DWG. NO.  
**AGL-64-C5118**

REV.  
**B**

# Bill Of Material

**Part #:** AGL-64-K4986      **Appl #:**      **Assy #:** AGLC5118      **BOM Rev:** H  
**Model #:**      **Rev:**      **Rev:** B      **Date:** 4/9/2003  
**Description:** BASE ELECTRICAL ASSY, ENCORE DHR

| Item: | Part #:      | Description:  | Qty: |
|-------|--------------|---|------|
| 0     | AGL-64-D4982 | BASE CONTROL SCHEMATIC, ENCORE DHR                        | REF. |
| 1     | AGL-XX-B4805 | POT. MTG. BRACKET   | 1    |
| 2     | AGL-XX-B4806 | SPEED ADJUST WHEEL  | 1    |
| 3     | AGL-64-A4930 | LABEL, TERMINAL BLOCK, ENCORE                             | 1    |
| 4     | AGL-XX-C4958 | SUBPANEL, ENCORE  | 1    |
| 5     | AGL-XX-B4981 | COVER, OUTLET   | 2    |
| 6     | AGL-64-D5367 | WIRE HARNESS, ENCORE, THROUGH                             | 1    |
| 7     | AGL-64-D5368 | WIRE HARNESS, ENCORE, LH CONTROL                          | 1    |
| 8     | AGL-64-D5369 | WIRE HARNESS, ENCORE, RH. CONTROL                         | 1    |
| 20    | 002728-01    | EMITTER, SERIES 10  | 2    |
| 21    | 002427-04    | SWITCH, FOOT, SPDT, MTD. IN GUARD, 16' CABLE              | 1    |
| 22    | 006016-05    | PLC, CPU MODULE, 12IN/8OUT, 24VDC                         | 1    |
| 24    | 006017-01    | SWITCH, MOMENTARY, ARROW, GREEN                           | 2    |
| 25    | 006006-60    | CIRCUIT BREAKER, 2 POLE, 60 AMP, PANEL MNT.               | 1    |
| 26    | 002099-10    | LABEL, .50 x 1.50, VINYL, SELF LAMINATING                 | 50   |
| 27    | 001883-05    | TERMINAL BLOCK, 35MM, 10-26 AWG, GRAY, UK5N 02M0381       | 51   |
| 28    | 001879-01    | DIN RAIL, 35MM WIDE, 7.5MM HIGH, 2 MT LG, NS35/7.5        | 30   |
| 30    | 000719-00    | WIRE, STRANDED, 10 AWG, BLACK                             | 5    |
| 31    | 006015-01    | SWITCH, ROCKER, SPST                                      | 2    |
| 32    | 001153-05    | CORD GRIP, BELL-MOUTH, BLACK, 5/8" MTG HOLE               | 2    |
| 33    | 001089-01    | CABLE TIE, NYLON, WHITE, 4" LG                            | 50   |
| 34    | 001090-01    | CABLE TIE, MOUNT, ADHESIVE-BACKED, 3/4" SQ                | 35   |
| 35    | 001876-10    | TERMINAL BLOCK, GND, 35MM, 8-20 AWG, USLKG10 29C3451      | 8    |
| 36    | 002544-02    | WIRE, THERMOCOUPLE, TYPE J, #20AWG,SHIELDED, 1000 FT ROLL | 30   |
| 37    | 002728-02    | RECEIVER, SERIES 10                                       | 2    |
| 38    | 001886-01    | BAR, JUMPER, 10-POS, #FB10-6 ( 10 pcs.per bag)            | 1    |
| 39    | 006015-02    | SWITCH, ROCKER, SPST, ILLUMINATED, GREEN                  | 3    |
| 40    | 000720-00    | WIRE, STRANDED, MTW, 6 AWG, BLACK                         | 2    |

**Part #:** AGL-64-K4986**Appl #:****Assy #:** AGLC5118**BOM Rev:** H**Model #:****Rev:****Rev:** B**Date:** 4/9/2003**Description:** BASE ELECTRICAL ASSY, ENCORE DHR

| Item: | Part #:    | Description:  | Qty: |
|-------|------------|---|------|
| 41    | 001089-02  | CABLE TIE, NYLON, WHITE, 5.5" LG                                | 15   |
| 42    | 001090-02  | CABLE TIE, MOUNT, ADHESIVE-BACKED, 1" SQ                        | 15   |
| 43    | 001875-01  | FUSE HOLDER, TERMINAL BLOCK, 35MM MTG, (NOW INCLUDES 001881-01) | 6    |
| 44    | 001881-01  | NOW PURCHASED AS PART OF 001875-01                              | 6    |
| 45    | 006021-30  | CIRCUIT BREAKER, 2 POLE, 30 AMP, DIN RAIL MNT                   | 2    |
| 46    | 001530-008 | FUSE, SLO-BLO, 3/4A, 250V, 1/4X1-1/4"                           | 2    |
| 47    | 001530-070 | FUSE, SLO-BLO, 7.0A, 250V, 1/4X1-1/4"                           | 2    |
| 48    | 006021-20  | CIRCUIT BREAKER, 2 POLE, 20 AMP, DIN RAIL MNT                   | 1    |
| 49    | 002507-04  | END COVER, TERMINAL BLOCK, D-UK4/10                             | 2    |
| 50    | 002542-04  | SLIP RING, 5 POLE, 3@45A, 2@2A, 2 BORE                          | 2    |
| 51    | 002728-03  | CABLE, SERIES 10, 2M LG.  | 3    |
| 52    | 001504-03  | TERMINAL, MALE, INSULATED, w/INSUL GRIP, 12-10 AWG              | 8    |
| 53    | 001503-02  | TERMINAL, FEMALE, INSULATED, w/INSUL GRIP, 16-14 AWG            | 9    |
| 54    | 001509-08  | TERMINAL, RING, INSULATED, BRAZED SEAM, 12-10 AWG, #10 STUD     | 8    |
| 55    | 001509-07  | TERMINAL, RING, INSULATED, BRAZED SEAM, 16-14 AWG, #6 STUD      | 8    |
| 56    | 000557-03  | PHMS, SLOTTED, #8-32UNC, 3/8 LG, ZINC                           | 8    |
| 57    | 000559-03  | PHMS, SLOTTED, #10-24UNC, 3/8 LG, ZINC                          | 4    |
| 58    | 000581-03  | PHMS, PHILLIPS, #10-32UNF, 3/8 LG, ZINC                         | 32   |
| 59    | 002509-60  | CONTACTOR, 3-POLE, 70A, 220V, 1 AUX                             | 1    |
| 60    | 002512-01  | LEGEND, HIGH VOLTAGE  | 2    |
| 61    | 002511-01  | ALARM, PANEL MTG, 3-28VDC                                       | 1    |
| 62    | 002448-02  | CORD GRIP, LIQUID-TIGHT, 1" NPT, 0.71-0.98 DIA, BLK             | 1    |
| 63    | 001966     | LUG, GROUNDING, 1/0-14AWG                                       | 1    |
| 64    | 001006-08  | NUT, LOCK, CONDUIT, 1"  | 1    |
| 65    | 000337-04  | HHCS, 1/4-20UNC, 1/2 LG, ZINC                                   | 1    |
| 66    | 000493-06  | WASHER, LOCK, 1/4 DIA, SPLIT, ZINC                              | 1    |
| 68    | 001826-04  | POWER SUPPLY, SINGLE, 24VDC, 2.4A                               | 1    |
| 69    | 001530-040 | FUSE, SLO-BLO, 4.0A, 250V, 1/4X1-1/4"                           | 2    |
| 70    | 000715-00  | WIRE, STRANDED, 18 AWG, BLACK                                   | 15   |

Part #: AGL-64-K4986

Appl #:

Assy #: AGLC5118

BOM Rev: H

Model #:

Rev:

Rev: B

Date: 4/9/2003

Description: BASE ELECTRICAL ASSY, ENCORE DHR

| Item: | Part #:   | Description:                                       | Qty:  |
|-------|-----------|--|-------|
| 71    | 002728-05 | CABLE, SERIES 10, 5M LG.                           | 1     |
| 72    | 006017-02 | SWITCH, MOMENTARY, BLANK, RED                      | 1     |
| 73    | 001352-06 | STANDOFF, HEX, M/F, #10-32UNC, 3/4 LG, AL          | 7     |
| 74    | 002523-08 | FERRULE, INSULATED, 18AWG, WIDE COLLAR             | 30    |
| 76    | 002523-02 | FERRULE, INSULATED, 14AWG, STD LENGTH, BLUE        | 2     |
| 77    | 000717-24 | WIRE, STRANDED, 14 AWG, GREEN/YELLOW               | 2     |
| 78    | 002955-01 | WIRE DUCT, 1 x 1-1/2, WHITE                        | 144.0 |
| 79    | 002955-02 | WIRE DUCT, 1 x 2-1/4, WHITE                        | 48.0  |
| 80    | 002955-04 | WIRE DUCT, 1-1/2 x 3, WHITE                        | 96.0  |
| 81    | 000343-08 | HHCS, 3/8-16UNC, 1 LG, ZINC                        | 4     |
| 82    | 000493-08 | WASHER, LOCK, 3/8 DIA, SPLIT, ZINC                 | 4     |
| 83    | 000201-03 | NUT, HEX, #8-32UNC, ZINC                           | 2     |
| 84    | 006030-01 | OUTLET, AC, SCREW MOUNT, .25 QD                    | 2     |
| 85    | 002523-06 | FERRULE, INSULATED, 6AWG, STD LENGTH, GREEN        | 6     |
| 86    | 002523-05 | FERRULE, INSULATED, 10AWG, STD LENGTH, BLACK       | 8     |
| 87    | 002523-10 | FERRULE, INSULATED, 12AWG, STD LENGTH, GRAY        | 2     |
| 88    | 002523-02 | FERRULE, INSULATED, 14AWG, STD LENGTH, BLUE        | 2     |
| 89    | 002951    | SIGNAL ISOLATOR                                    | 1     |
| 90    | 002512-07 | LEGEND, DANGER PINCH POINT (2.5x4)                 | 4     |
| 91    | 002512-03 | LEGEND, DO NOT OPERATE WITHOUT GUARDS IN PLACE     | 2     |
| 92    | 002512-08 | LEGEND, DANGER HOT (2.5x4)                         | 2     |
| 93    | 002727-01 | CONNECTOR, 90 DEG. FLAG DISCONNECT 16-14AWG        | 2     |
| 94    | 002727-02 | CONNECTOR, 90 DEG. FLAG DISCONNECT 12-10AWG        | 2     |
| 95    | 002506    | SWITCH ASSY, PUSHBUTTON, E-STOP                    | 4     |
| 96    | 006018-01 | SWITCH, PUSHBUTTON, BLACK, 5/8 DIA.                | 1     |
| 97    | 006019-01 | LED, PILOT LIGHT, GREEN, 1/2 DIA. SNAP IN          | 1     |
| 98    | 001998-03 | CONTROLLER, MOTOR, 240V INPUT, 90 or 180VDC OUTPUT | 1     |
| 99    | 001625-05 | CONTROLLER, TEMP, THERMOCOUPLE, PULSED, ALARM      | 2     |
| 100   | 001623-50 | RELAY, 50A, 240V, 1-PHASE                          | 4     |



**Part #:** AGL-64-K4986

**Appl #:**

**Assy #:** AGLC5118

**BOM Rev:** H

**Model #:**

**Rev:**

**Rev:** B

**Date:** 4/9/2003

**Description:** BASE ELECTRICAL ASSY, ENCORE DHR

| <b>Item:</b> | <b>Part #:</b> | <b>Description:</b>                              | <b>Qty:</b> |
|--------------|----------------|--|-------------|
| 101          | 006004-67      | RIBBON SWITCH, 4' LEADS, 4 WIRE, YELLOW, 67" LG. | 2           |
| 102          | 002974-02      | RELAY, MIDGET, 1PDT, 24VDC                       | 1           |
| 103          | 002337-06      | SOCKET, RELAY, 5-PIN, DIN RAIL MTG               | 1           |
| 104          | 012393         | DOUBLE SIDED TAPE                                | 134         |
| 105          | 002345-221     | RESISTOR, METAL-FILM, 1%, 1/4W, 221 OHM          | 1           |
| 107          | 002243-04      | HOLE PLUG, ENCLOSURE, 1/2"                       | 1           |
| 108          | 006033-02      | CONNECTOR, BRASS/SETSCREW, 2-10AWG               | 4           |
| 109          | 006033-03      | CONNECTOR, BRASS/SETSCREW, 2-14AWG               | 4           |
| 110          | 000573-03      | PHMS, PHILLIPS, #4-40UNC, 3/8 LG, ZINC           | 2           |
| 111          | 002893-02      | END BARRIER, FUSE BLOCK                          | 1           |
| 112          | 000053-02      | BHSCS, #6-32UNC, 1/4 LG, BLACK                   | 4           |

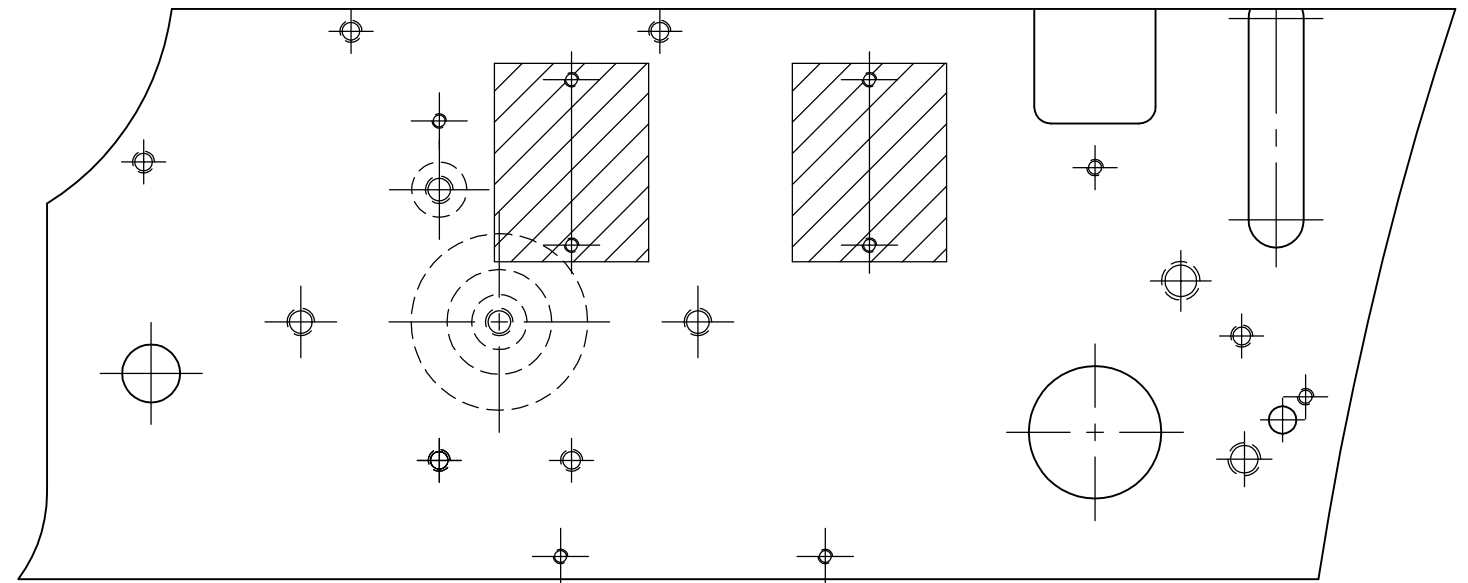
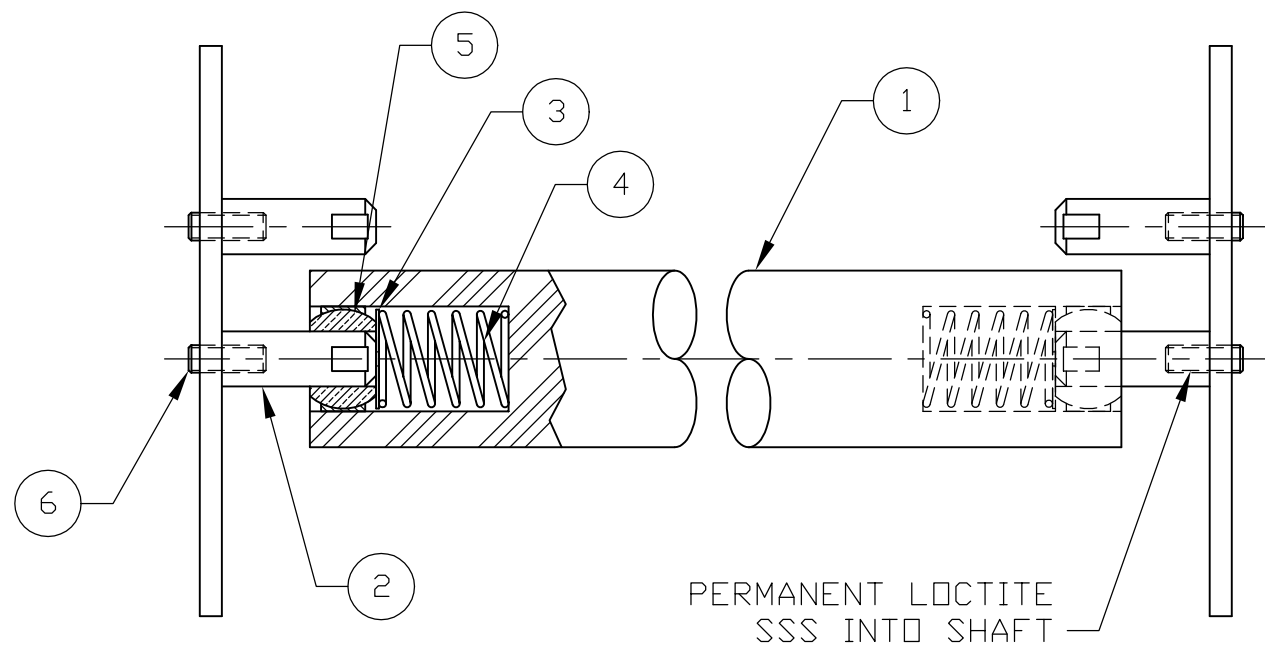

*BREAK ALL SHARP EDGES*

DO NOT SCALE DWG.



Advanced Greig Laminators, Inc.  
801 Burton Blvd.  
DeForest, WI 53532

UNLESS OTHERWISE SPECIFIED

MAT'L:  
AGLK4824-1

MOVABLE IDLER ROLLER  
ASSEMBLY, DHR

0.00 +/-0.015  
0.000 +/-0.005

FINISH:

ANGLES +/- .5°

|         |      |          |        |
|---------|------|----------|--------|
| JOB NO. | QTY. | DWG. BY. | CHK BY |
|         |      | GFT      |        |

SCALE: 1/2 = 1

DWG. NO.

REV.

DATE: 11-06-03

AGL-64-B4747-1

| REV NO. | DESCRIPTION | DATE | INT. | ECN |
|---------|-------------|------|------|-----|
|         |             |      |      |     |

---

# Bill Of Material

---

**Part #:** AGL-64-K4824-1

**Appl #:**

**Assy #:** AGLB4747-1

**BOM Rev:** -

**Model #:**

**Rev:**

**Rev:** -

**Date:** 11/6/2003

**Description:** MOVABLE IDLER ASSEMBLY, DHR

---

| Item: | Part #:      | Description:  | Qty: |
|-------|--------------|---|------|
| 1     | AGL-64-B4745 | MOVABLE IDLER ROLLER  | 1    |
| 2     | AGL-XX-B4746 | SHAFT, IDLER ROLLER   | 4    |
| 3     | 012404-01    | WASHER, 1.120 OD. x .160 ID. x .03 THK, SST                     | 2    |
| 4     | 012405-05    | SPRING, COMPRESSION, 1.095 OD, 0.082 THICK, 1.75 LG, MUSIC WIRE | 2    |
| 5     | 012406-10    | BEARING, SPHERICAL, 5/8 BORE COM-10                             | 2    |
| 6     | 000133-14    | SSS, CUP PT, 5/16-18UNC, 7/8 LG, BLACK                          | 4    |

---

---

# Bill Of Material

---

**Part #:** AGL-XX-K2660

**Appl #:**

**Assy #:**

**BOM Rev:** C

**Model #:**

**Rev:**

**Rev:**

**Date:**

**Description:** ACCESSORIES KIT, 44/4400/64 SERIES/6400/6450

---

| Item: | Part #:    | Description:                               | Qty: |
|-------|------------|--|------|
| 1     | 012235-01  | CUTTER, ZIPPY                              | 1    |
| 2     | 012236-01  | ROLL ADHESIVE ERASER, PLAIN, SHRINKWRAPPED | 1    |
| 3     | 001446-04  | ALLEN WRENCH, LONG ARM, 3/32, T-HANDLE     | 1    |
| 5     | 001446-11  | ALLEN WRENCH, LONG ARM, 1/4 T-HANDLE       | 1    |
| 7     | 012248     | CLOTH, LOW LINT, 12x13                     | 1    |
| 8     | 012249     | ALCOHOL, ISOPROPYL, 1 PINT                 | 1    |
| 10    | 001530-070 | FUSE, SLO-BLO, 7.0A, 250V, 1/4X1-1/4"      | 2    |
| 11    | X6         | OPERATORS MANUAL                           | 1    |

---

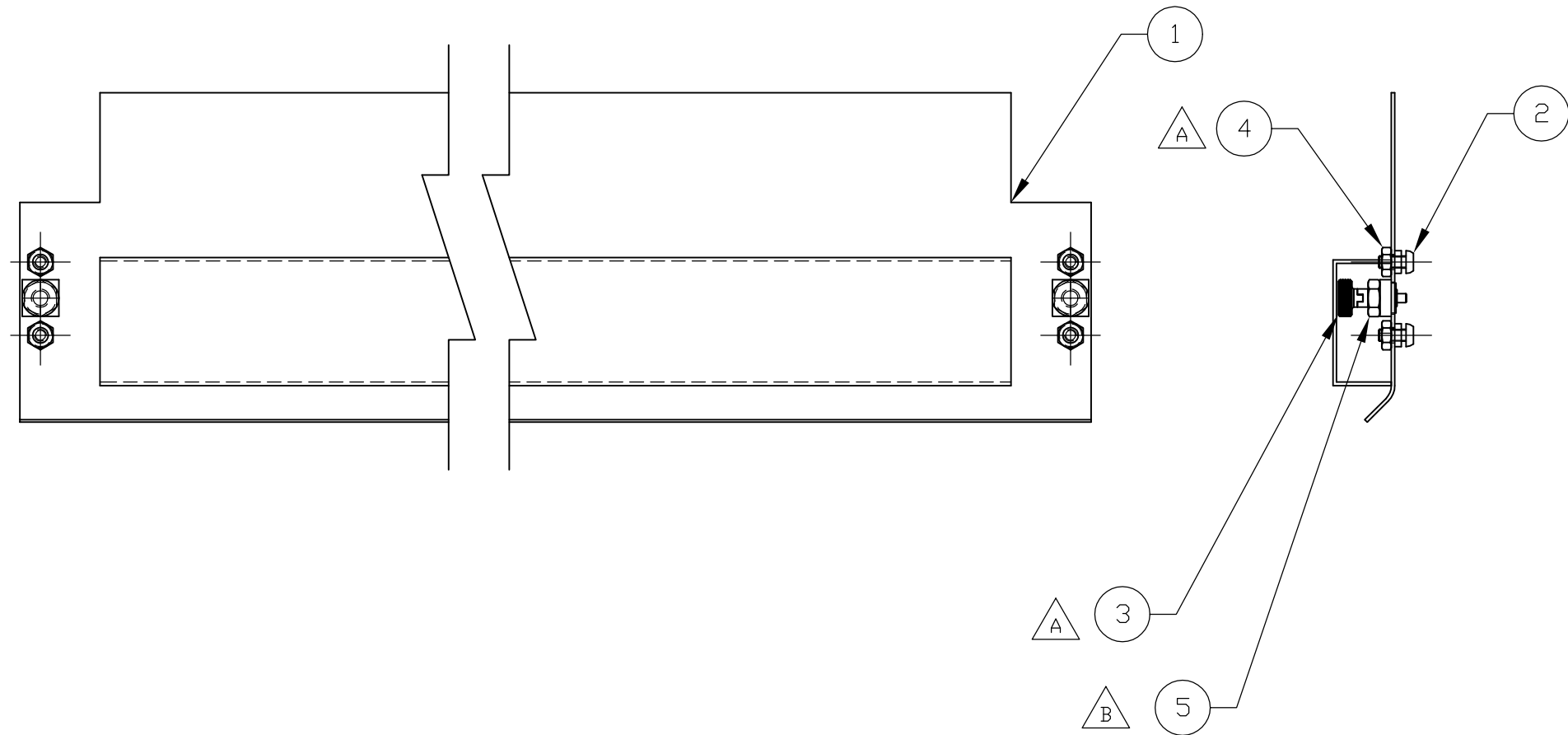

LOC TITE IN THE BHSCS  
 WITH BLUE LOC TITE. LEAVE  
 APPROX .06 GAP FOR REMOVABLE  
 TABLE, AND .10 GAP FOR EASY WEB  
 TABLE.

|                                  |                                  |      |                 |                          |  |
|----------------------------------|----------------------------------|------|-----------------|--------------------------|--|
| <i>BREAK ALL SHARP EDGES</i>     |                                  |      |                 |                          |  <b>Advanced Greig Laminators, Inc.</b><br>801 Burton Blvd.<br>DeForest, WI 53532 |
| DO NOT SCALE DWG.                |                                  |      |                 |                          |  |
| UNLESS<br>OTHERWISE<br>SPECIFIED | MAT'L:<br>AGLK5033<br>AGLK5033-1 |      |                 |                          | INFEED HOLD DOWN<br>ASSEMBLY,  |
|                                  | FINISH:                          |      |                 |                          |  |
| 0.00 +/-0.015<br>0.000 +/-0.005  | JOB NO.                          | QTY. | DWG. BY.<br>GFT | CHK BY.                  | SCALE: 1/2 = 1<br>DATE: 4-25-03  |
| ANGLES +/- .5°                   |                                  |      |                 | DWG. NO.<br>AGL-64-B5034 | REV.<br>B  |

| REV<br>NO. | DESCRIPTION   | DATE    | INT. | ECN |
|------------|---------------|---------|------|-----|
| B          | ADDED JAM NUT | 9-17-07 | GFT  |     |
| A          | ADDED #3 & 4  | 9-25-06 | GFT  |     |

---

# Bill Of Material

---

**Part #:** AGL-64-K5033

**Appl #:**

**Assy #:** AGLB5034

**BOM Rev:** A

**Model #:**

**Rev:**

**Rev:** B

**Date:** 4/25/2003

**Description:** INFEEED HOLD DOWN ASSEMBLY, ENCORE SERIES

---

| Item: | Part #:         | Description:                             | Qty: |
|-------|-----------------|--|------|
| 1     | AGL-64-C2904-02 | INFEEED HOLD DOWN, ENCORE SERIES (WHITE) | 1    |
| 2     | 000055-03       | BHSCS, #8-32UNC, 3/8 LG, BLACK           | 4    |
| 3     | 012143-08       | PLUNGER, KNURLED KNOB,LOCKING, 1/4-20UNC | 2    |
| 4     | 000201-03       | NUT, HEX, #8-32UNC, ZINC                 | 4    |

---